

KURZ INSTRUMENTS, INC.

**KURZ™
AIR FLOW METER
WITH
MODEL 435R₁
SYSTEM TRANSMITTER
CALIBRATION
MANUAL**

Written By: Thomas Kobayashi, Jr., Technical Writer

Document Number: 360190, Rev. C
Copyright © 1991 Kurz Instruments, Inc.



Kurz Instruments, Inc.
2411 Garden Road
Monterey, CA 93940

(408) 646-8901 Fax.
(800) 424-7356 Tel.

Document Title: Kurz™ Air Flow Meter with Model 435R₁ System Transmitter
Calibration Manual

Document Number: 360190, Rev. C

Publication Date: April 1991

Copyright© 1991. All rights reserved. No part of this publication may be stored in a retrieval system, transmitted or reproduced in any way, including but not limited to photocopy, photograph, magnetic or other record, without the prior agreement and written consent of Kurz Instruments, Inc.

Every effort has been made to supply complete and accurate information. However, Kurz Instruments, Inc. assumes no responsibility for its use, nor for any infringements of patents or other third parties which would result. In addition, makes no representations or warranties of any kind concerning the contents of this publication. Under no circumstances will Kurz Instruments, Inc. be liable for any loss or other damages pertaining to the use of this publication.

Publication is generic in nature. No guarantee is made that the publication conforms to the particular equipment produced for a particular application. As-built publication entails an additional charge. Factory and on-site training in the use and operation of Kurz's products may be made available at the buyer's expense, subject to agreement by Kurz Instrument, Inc.

The information contained in this publication is subject to change without notice. Kurz Instruments, Inc. reserves the right to make engineering changes and product improvements at any time and without prior notice. Consult your local Kurz representative or a factory application engineer for information regarding current specifications.

Equipment sold by Kurz Instruments, Inc. is not intended for use in connection with any nuclear facility or activity unless covered by a specific quotation where the conditions of such usage will be detailed. If the equipment is used in a nuclear facility or activity without supporting quotation, Kurz disclaims all liability for any damage, injury, or contamination, and the buyer shall indemnify and hold Kurz, its officers, agents, employees, successors, assigns, and customers, whether direct or indirect, harmless from and against any and all losses, damages, or expenses of whatever form or nature (including attorney's fees and other costs of defending any action) which they, or any of them, may sustain or incur, whether as a result of breach of contract, warranty, tort (including negligence), strict liability or other theories of law, by reason of such use.

Kurz, MetalClad, and DuraFlo are trademarks of Kurz Instruments, Inc.

Limited Warranty—

Kurz's products are warranted to be free from defects in material and workmanship for a duration of one year from the date of shipment from the Kurz factory. Kurz's obligation is limited to repairing, or at its option, replacing products and components which, on verification, prove to be defective at the Kurz factory in Monterey, California. Kurz Instruments, Inc. shall not be liable for installation charges, for expenses of buyer for repairs or replacement, for damages from delay or loss of use, or other indirect or consequential damages of any kind. Kurz Instruments, Inc. extends this warranty only upon proper use and installation of its products in the particular application for which it is intended and quoted and this warranty does not cover Kurz's products that have been serviced or modified by any person or entity other than Kurz Instruments, Inc. and its authorized service technicians. This warranty does not cover Kurz's products that have been subjected to unusual physical or electrical stress, or alteration, or tampering, or upon which the original identification marks have been removed or altered. Kurz Instruments, Inc. shall not be liable for the normal wear of any seals in its products and further shall not be liable for the deterioration of seals based on any usage of its products with gases other than air, or unless otherwise specified in the contract.

Transportation charges for material shipped to the Kurz factory for warranty repair are to be paid for by the shipper. Kurz Instruments, Inc. will return items repaired or replaced under warranty prepaid. No items shall be returned for warranty repair without prior written authorization from the Kurz factory.

Table of Contents

Section 1: Introduction

- 1.1 General Overview1-1
- 1.2 Principle of Calibration1-2

Section 2: Setup

- 2.1 Procedure2-1
- 2.2 Equipment2-2

Section 3: Procedures for Calibration

- 3.1 Recording Flow Rates3-1
- 3.2 Recording Inches of Water3-2
- 3.3 Recording Current-Sense Voltage Signals3-7
- 3.4 Adjustments to the Nonlinear Circuitry3-8
 - 3.4.1 Calculating Resistant Values for R₁₇ and R₂₃3-8
 - 3.4.2 Calibrating the Nonlinear Circuitry3-9
 - 3.4.3 Verifying the Nonlinear Voltages3-11
- 3.5 Graphing Data Points3-12
 - 3.5.1 Plotting the Nonlinear Voltages on a Graph3-12
 - 3.5.2 Plotting Break-Point Voltages on the Curve3-15
- 3.6 Adjustments to the Linear Circuitry3-17
 - 3.6.1 Calibrating the Linear Circuitry3-17
 - 3.6.2 Verifying the Linear Voltages3-20
 - 3.6.3 Adjustments to the Optional Signal Output3-24

Section 4: Maintenance and Trouble-Shooting

4.1 Maintenance4-1

 4.1.1 Electronics Maintenance4-1

 4.1.2 Sensor Maintenance4-2

4.2 Trouble-Shooting4-3

 4.2.1 Test Procedure for the Model 435R₁ Power
 Supply and Analog Linearizer Board4-4

 4.2.2 Testing the Model 465R_x Current-Transmitter
 Board4-6

Section 5: Appendices

- Appendix A: Engineering Drawings
- Appendix B: Trouble-Shooting Guide

Section 1: Introduction

1.1 General Overview

The calibration procedures¹ reviewed in this manual pertain to the Kurz air flow meter which comprises of a Model 435R₁ Power Supply and Analog Linearizer Board and a Kurz thermal mass flow sensor, whether it be a Series 450 Insertion Mass Flow Element or a Series 500 In-Line Mass Flow Element. In association with the sensor is a Model 465R_x Current-Transmitter Board serialized with a corresponding identification number.

Note: The sensor and its associated bridge circuitry on the current-transmitter board are matched by serial number. This is due to the technical aspect of the bridge circuit being set up during a part of the calibration process at the Kurz factory we call *temp comp*. In general, the process consists of determining the balance point of the bridge circuit in reference to the amount of power supplied to the velocity winding (R_p , for resistor, probe) to maintain a constant temperature differential or overheat, above the temperature of the passive temperature compensation winding, we call R_{tc} , for resistor, temperature compensation. Thus, in no event should a sensor be interchanged with an unmatched current-transmitter board.

The calibration procedures are only applicable with the Kurz Instruments' Series 400 Air Velocity Calibration Systems; i.e., the 400A, 400B and 400BL Models (vacuum devices); and the 400B-P and 400C-P Models (pressure devices).

As a prerequisite course to performing the calibration procedures, you should review and perform the maintenance and trouble-shooting procedures discussed in Section 4. It is recommended that the unit be returned to the Kurz factory if repairs are needed. This is usually the most cost effective and reliable means.

¹ Given that "temp comp" is current (I) mode, the calibration procedure doesn't comply with Kurz air flow meters "temp comp" for voltage (E) mode. Though, similarities in the preliminary phases of the procedures for calibration do exist for E-mode, we recommend that you consult with the Customer Service Dept. at Kurz Instruments, Inc. for procedures pertaining to E-mode system configuration to simplify the calibration procedures.

1.2 Principle of Calibration — An Overview

The Kurz air flow meter is calibrated in a Series 400 Air Velocity Calibration System with reference to a precise, NIST-traceable laminar-flow type mass flow meter used to measure the total air flowing through the calibrator. This air flows through a well-shaped nozzle to form a free-jet of air having a very uniform, flat velocity profile, which is provided by a flow straightener and air filter. The Kurz thermal mass flow sensor is inserted in the center of a free-jet of air (the free-jet is external with the Model 400B-P and C-P calibrators)². Turbine-type vacuum supplies are used to "pull" the air flow through the test section except for a Model 400B-P and C-P calibrators where the air flow is "pushed". By varying the voltage to the motor(s) by means of a variable autotransformer, the velocity of the free-jet of air impinging on the sensor may be adjusted over the full range. A precise, inclined water manometer is used to measure the differential pressure (ΔP) across the pressure taps in the mass flow meter section of the Model 400 calibrator. This differential pressure is measured, corrected for nonstandard conditions and the air velocity is determined through the use of the calibration data supplied³.

As for the system's technical aspect of calibration, dependent on the amount of air velocity measured by the Kurz thermal mass flow sensor, the current-return signal from the Model 465Rx Current-Transmitter Board (range of 100 to 600 mA) is drawn across a resistor (R_8) on the Model 435R₁ Power Supply and Analog Linearizer Board, resulting in a current-sense voltage signal (range of 0.600 to 3.000 Vdc). This current-sense voltage signal at zero and specified maximum flow rate are then adjusted in the nonlinear circuitry of the linearizer board in association with the "zero" and "span" control-potentiometers to a nonlinear 0.000 to 5.000 Vdc signal. The nonlinear voltages for each calibration point or flow rate are recorded and then plotted on a curve; whereas, break-point voltages are plotted on the same curve and linear voltage points are selected in retrospect to the break-point voltages on the curve to be used in linearizing the nonlinear signal.

- 2 Center of velocity winding (R_p) should be at a point of average flow (normally at center-line of nozzle).
- 3 Local temperature and barometric pressure are measured, and correction factors are applied to correct to standard conditions referenced to a temperature of +77° Fahrenheit (F) or +25° Celsius (C) and an atmospheric pressure of 29.92 inches (760 mm) of mercury (Hg).

The linearizer circuitry on the linearizer board being an analog offset type, the number of amplifier stages shift the linear voltage points up or down to approximate a linear curve within the range of a linear 0.000 to 5.0000 Vdc signal that is in direct representation to the amount of air flow being measured by the sensor: 0.000 Vdc represents no flow conditions, 2.500 Vdc indicates a representation of flow exactly half of the maximum flow, and 5.000 Vdc represents maximum flow.

Note: There is a maximum on one current-return signal input per linearizer board; however, a maximum of two analog outputs. One output is scaled 0.000 to 5.000 Vdc for the selected velocity or mass flow calibration; whereas, the other is scaled for mass flow rate for specified duct or pipe area, flow profile factor⁴, and full scale flow rate and units.

WARNING: Kurz Instruments, Inc. will NOT perform a free calibration, while the Kurz air flow meter is still under warranty, if you have already made adjustments to the "zero", "span" and, or other linearization controls.

End of Section 1

⁴ The profile factor is the ratio of the duct or pipe average velocity to the velocity value measured by the Kurz thermal mass flow sensor.



Section 2: Setup

2.1 Procedure

The inclined water manometer should be mounted on a wall, filled with fluid, and levelled by following the instructions enclosed with the manometer. Two tubing adapters and two sections of vinyl tubing are supplied; connect the downstream pressure tap of the mass flow meter section of the Model 400 calibrator to the "high" end of the manometer and the upstream pressure tap to the "low" end of the manometer. The Model 400 calibrator should be used in a safe working area and preferably on a laboratory bench. For connections between the motor(s) and the variable autotransformer(s), refer to the instructional manual enclosed with the Model 400 calibrator. The sensor to be calibrated is inserted through the compression fitting such that the center of the velocity winding (R_p) is in the center of the calibrator body and aligned to face directly upstream. (Note: Compression fittings are not required for the 400B-P and 400C-P Models since it calibrates externally; however, to achieve better results and accuracy, align the sensor three inches from the nozzle of the nozzle section.)

Note: If you are using a laminar flow element (LFE) to calibrate a Series 500 In-Line Mass Flow Element, the long end of the unsymmetrical flow body is installed in-line with and downstream from the LFE; i.e., the air flow enters through the long end of the flow body and exits through the short end. A flow control valve is connected to the shorter end of the flow body and a vacuum source is attached to the flow control valve. In most cases, unless otherwise specified, the flow body is orientated in a horizontal run with the flow transmitter enclosure or junction box extending straight up.

2.2 Equipment

Basically, the following accessories will be required for the calibration procedures:

- a) A calibrated digital voltmeter (DVM) accurate to ± 0.001 Vdc.
- b) A flat-bladed screwdriver with a narrow blade and preferably with a long shaft.
- c) A Model 400 calibrator and supplied Meriam LFE curve.
- d) A thermometer placed in such a way as to accurately determine the immediate temperature of the air flowing through the test section of the mass flow meter (NIST-traceable), and an absolute barometer to measure actual pressure in the approximate area.
- e) A Kurz calibration work sheet for recording calibration information. (Note: A sample Kurz calibration work sheet is provided in Appendix A.)
- f) A Kurz air flow meter and for recalibration purposes, the provided Calibration Data and Certification Sheet.

End of Section 2

Section 3: Procedures for Calibration

NOTICE: A completed Kurz calibration work sheet has been provided and can be found at the end of this section. The work sheet comprises of recorded data in reference to each calibration procedure in discussion. The primary objective serves to facilitate any complications (such as misinterpretation or ambiguousness of text). Please refer to this work sheet for reference purposes only.

3.1 Recording Flow Rates

If this is a recalibration, the flow rates in velocity and, or mass flow are listed on the Calibration Data and Certification Document enclosed with the Kurz air flow meter. Refer to the appropriate serial number on the document corresponding to the matching equipment.

The following steps describe the procedure for obtaining the flow rates for a desired flow range:

- Step 1. Record the selected maximum flow rate for calibration point 11 in the "Flow Rate" column. (Note: You will be required to record the remaining flow rates.)
- Step 2. Divide this maximum flow rate by 10. The value calculated will be used as the decremental value; e.g., if the maximum flow rate is 1500 standard feet-per-minute (SFPM), then the decremental value is 150.
- Step 3. To obtain the flow rate for calibration point 10, subtract the decremental value from the maximum flow rate.
- Step 4. Continue to subtract the decremental value from each preceding calibration point until you have calculated the flow rate for calibration point 2.
- Step 5. After you have calculated the flow rate for calibration point 2, divide this flow rate by half to obtain the flow rate for calibration point 1.
- Step 6. Zero flow rate will be a value of 0 in calibration point 0.

3.2 Recording Inches of Water

A. From the Meriam LFE curve supplied with the Model 400 calibrator, find the differential pressure (H_s) corresponding for each flow rate recorded in the "Flow Rate" column. Record each value in the "Inches of H₂O" column for calibration points 0 through 11.. Refer to Figure 3.2-1 for an example of a Meriam LFE curve in cubic-feet-per-minute (CFM).

Note:

$$Velocity = \frac{SCFM}{LFE\ Area} = SFPM$$

Whereas:

$$Mass\ Flow = SFPM \times LFE\ Area = SCFM$$

Figure 3.2-1
Example of a Calibration Curve

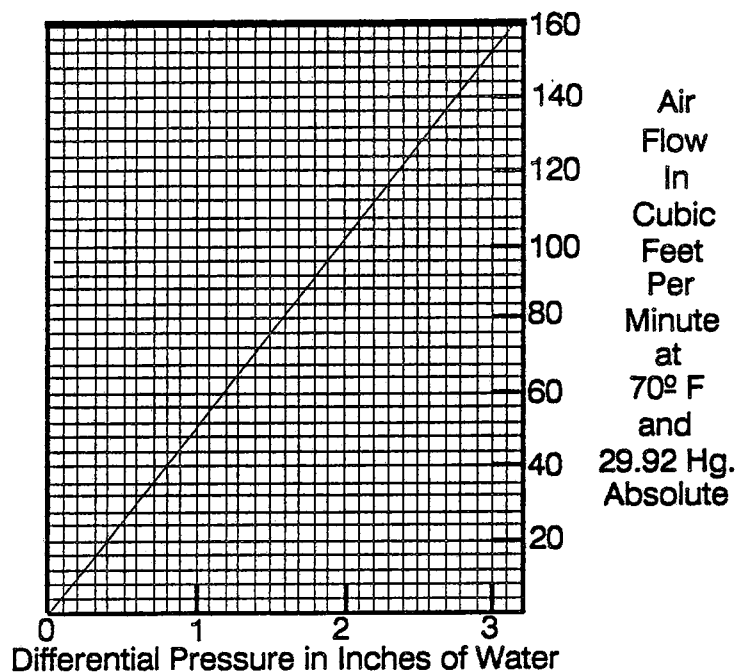

B. The next procedure consists of adjusting the air flow through the test section of the Model 400 calibrator. The flow will be adjusted to a specific level on the manometer. The manometer reflects flow rates according to the inches of water.

Note: If not already set, adjust the manometer to read 0.0 inches of water at zero flow rate.

However, to obtain the desired flow rates in the "Flow Rate" column, you must initially determine the temperature and pressure correction factor for the mass flow meter section; in other words, the Kurz thermal mass flow sensor, unlike the Model 400 calibrator, is a mass flow instrument and will provide readings of a flowing gas relative to a standard temperature and pressure (STP), regardless of the actual temperature and pressure. Therefore, you will need to correct for actual temperature and pressure to STP. The temperature correction factor (T_{cf}) is shown in Chart A. The pressure correction factor (P_{cf}) is the ratio of the true absolute pressure (P_a) at the inlet to the Model 400 calibrator (normally this is the same as the barometric pressure) to the standard atmospheric pressure (P_s) of 29.92 inches of Hg. Thus:

$$P_{cf} = \frac{P_a}{P_s}$$

The external flow air velocity calibrators (400B-P and 400C-P Models), are pressure devices rather than vacuum devices resulting in an external free-jet. With this principle in mind, a conversion constant (13.6) is used in the pressure correction equation. Therefore:

$$P_{cf} = \frac{\left(\frac{H_s}{13.6} \right) + P_a}{P_s}$$

Chart A
Temperature Correction Factor (T_{cf})
Air Base Temperature 25° C

AIR TEMPERATURE CORRECTION CHART										
°F	+0	+1	+2	+3	+4	+5	+6	+7	+8	+9
50	1.0848	1.0810	1.0773	1.0735	1.0698	1.0661	1.0625	1.0583	1.0552	1.0516
60	1.0480	1.0444	1.0409	1.0373	1.0039	1.0303	1.0269	1.0234	1.0200	1.0165
70	1.0132	1.0097	1.0064	1.0031	.9997	.9964	.9931	.9899	.9866	.9833
80	.9802	.9769	.9738	.9705	.9674	.9643	.9611	.9581	.9549	.9519
90	.9489	.9548	.9428	.9397	.9368	.9338	.9308	.9279	.9250	.9220

Note: In some cases, there is a need to correct from actual temperatures to standard temperatures referenced to 0° C and 1 BAR pressure; for instance, European countries where nominal units are applicable. The temperature correction factor (T_{cf}) is shown in Chart B.

Chart B
Temperature Correction Factor (T_{cf})
Air Base Temperature 0° C

AIR TEMPERATURE CORRECTION CHART										
°F	+0	+1	+2	+3	+4	+5	+6	+7	+8	+9
50	.9939	.9905	.9870	.9836	.9801	.9768	.9735	.9701	.9668	.9634
60	.9602	.9568	.9536	.9503	.9472	.9439	.9408	.9376	.9345	.9313
70	.9283	.9251	.9220	.9190	.9159	.9128	.9099	.9069	.9038	.9009
80	.8980	.8950	.8921	.8892	.8863	.8834	.8805	.8778	.8749	.8721
90	.8693	.8665	.8637	.8610	.8583	.8555	.8528	.8501	.8474	.8447

If it is assumed there are a certain amount of air velocities to be set up in the Model 400 calibrator, the correct differential pressure drop (ΔP) across the flow meter section must be determined. Differential pressure (H_s) in inches of water corresponds to air velocity. Because present conditions will probably be different than the basis for the calibration (25° C and 29.92 inches Hg) the indicated differential pressure (H_{ind}) must be determined as follows using the temperature (T_{cf}) and pressure (P_{cf}) correction factors:

$$H_{ind} = \frac{H_s}{P_{cf} \times T_{cf}}$$

Example: Establish the proper differential pressure to set up an air velocity of 1500 SFPM. The air temperature at the inlet to a Model 400B calibrator is 90° F and the absolute pressure is 29.00 inches of Hg. Find H_{ind} .

- a) From Chart A, $T_{cf} = 0.9489$
- b) $P_{cf} = \frac{29.00}{29.92} = 0.96925$
- c) From Figure 3.2-1, $H_s = 1.720 \text{ inches of water}$
- d) Therefore, $H_{ind} = \frac{1.720}{0.9489 \times 0.96925} = 1.870 \text{ inches of water}$
- e) Adjust the variable transformer(s) to obtain exactly 1.870 inches of water in the manometer.

C. If you wish to know the actual air velocity instead of the "standard" air velocity referenced to 29.92 inches Hg and 25° C. The following equation may be used:

$$V_a = \left(\frac{\rho_s}{\rho_a} \right) \times V_s$$

Where,

V_a = velocity in actual feet-per-minute

V_s = standard velocity in feet-per-minute (SFPM)

ρ_s = standard air density

ρ_a = actual air density

Another way to write the above equation is:

$$V_a = \left(\frac{P_s \times T_s}{P_a \times T_a} \right) \times V_s = 0.05578 \left(\frac{T_a}{P_a} \right) \times V_s$$

Where,

P_s = 29.92 inches Hg pressure

P_a = actual barometric pressure (in Hg)

T_s = 25° C = 536.4° R (Rankine)

T_a = actual temperature in ° R (° R = ° F + 459.4)

3.3 Recording Current-Sense Voltage Signal

Before initiating this procedure, you will be required to check the bridge voltage (B.V.) on the Model 465R_x Current-Transmitter Board; in addition, record the voltage measurement at zero flow rate and of the known air velocity at maximum flow rate. Therefore, refer to Section 4: *Trouble-Shooting*, for your appropriate current-transmitter board and the test point placement for measuring B.V.

CAUTION: If the B.V. is 5.000 Vdc or more (with no air flow impinging on the sensor), and the voltage does not start to alleviate below 5.000 Vdc within 10 seconds, turn power OFF, immediately. Supplying power for more than 10 seconds under these conditions may result in damage to the sensor.

Note: The Kurz air flow meter must be operational, and a calibrated digital voltmeter (DVM) accurate to within ± 0.001 Vdc must be connected between terminal block 1, terminal screw 3 (TB1-3; GND) and terminal block 1, terminal screw 9 (TB1-9; I RET).

Step 1. Check to make sure that no air flow conditions are present; i.e., the test section of the Model 400 calibrator is at zero flow. Allow the sensor and associated circuitry to stabilize. (**Note:** For an external flow air velocity calibration, cover the protective window of the sensor to prevent any air flow to impinge on the sensor.)

Step 2. While monitoring the current-sense voltage signal at TB1-9, record the voltage measurement for calibration point 0 in the "Current-Sense DC Voltage" column for zero flow rate.

Note: You should check for current-sense voltage signal immediately due to after several minutes at zero flow in a small air volume, the heat produced by the R_p winding begins to affect the R_{tc} winding.

Step 3. For calibration points 1 through 11, starting with the maximum flow rate, execute Steps 1 through 5 in Subsection 3.2, Part B. Remember to record the current-sense voltage signal for each calibration point in the "Current-Sense DC Voltage" column.

3.4 Adjustments to the Nonlinear Circuitry

3.4.1 Calculating Resistant Values for R17 and R23

This procedure consists of calculating resistant values for resistors R17 and R23 in the nonlinear section: R17 is for the "zero" control-potentiometer; whereas, R23 is for the "span" control-potentiometer. Both R17 and R23 are located below the "zero" and "span" control-potentiometers, as shown in Figure 3.4-1.

Formula to obtain the resistant value for R17:

$$R_{17} = \frac{50}{X} - 1 = \text{Value in } K\Omega$$

Formula to obtain the resistant value for R23:

$$R_{23} = \frac{1}{(Y-X)} \times 45.45 - 1 = \text{Value in } K\Omega$$

Where,

X= Current-sense voltage signal at zero flow rate

Y= Current-sense voltage signal at maximum flow rate

After calculating for correct resistance and solder R17 and R23 on the linearizer board. Refer to Figure 3.4-1 for the resistor placements.

3.4.2 Calibrating the Nonlinear Circuitry

The next procedure is to adjust the current-sense voltage signals at zero flow rate and maximum flow rate to a nonlinear voltage signal; i.e., adjust the "zero" control-potentiometer (R19) at zero flow rate to a nonlinear 0.000 Vdc signal and adjust the "span" control-potentiometer (R21) while monitoring the known air velocity at specified maximum flow rate to a nonlinear 5.000 Vdc signal. Refer to Figure 3.4-1 for the control-potentiometer placements and test point locations on the linearizer board.

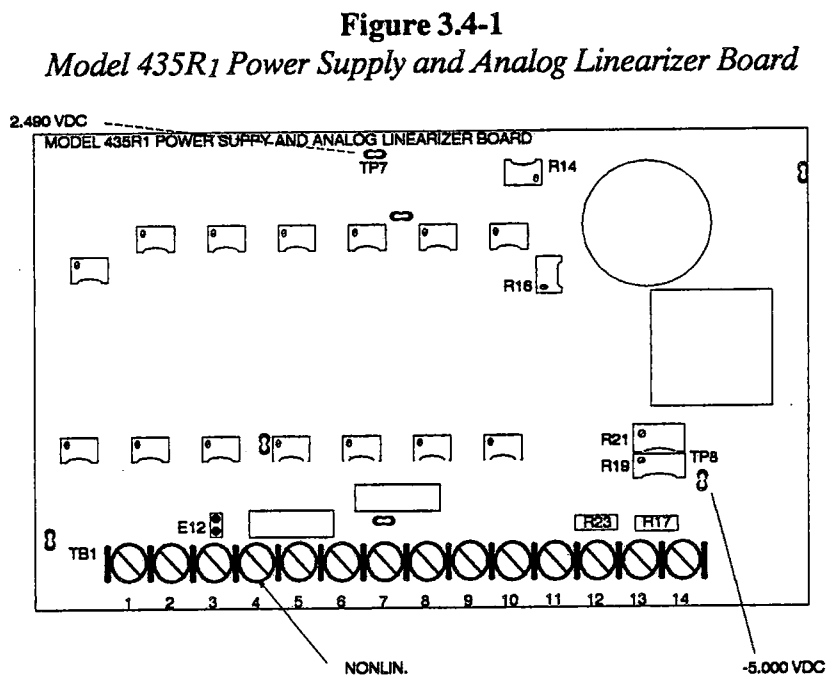

- Step 1. Immediately after powering up the Kurz air flow meter, check the internal 2.490 Vdc reference voltage. Measure the voltage between terminal block 1, terminal screw 3 (TB1-3; GND) and test point 7 (TP7). The voltage measured should be 2.490 Vdc \pm 5.0%. If necessary, adjust the control-potentiometer (R14) up or down until you get a reading of 2.490 Vdc.

- Step 2. Next, check the internal -5.000 Vdc reference voltage. Measure the voltage between TB1-3 (GND) and test point 8 (TP8). The voltage measured should be -5.000 Vdc \pm 5.0%. If necessary, adjust the control-potentiometer (R16) up or down until you get a reading of -5.000 Vdc.
- Step 3. Check to make sure that no air flow conditions are present; i.e., the test section of the Model 400 calibrator is at zero flow. Allow the sensor and associated circuitry to stabilize. (Note: For an external flow air velocity calibration, cover the protective window of the sensor to prevent any air flow to impinge on the sensor.)
- Step 4. Check the nonlinear voltage between terminal block 1, terminal screw 4 (TB1-4; NONLIN.) and TB1-3 (GND), adjust R19 up or down until you get a reading of 0.000 Vdc. (Note: Record this value for calibration point 0 in the "Actual Nonlin. Vdc" column.
- Note: You should check for 0.000 Vdc immediately due to after several minutes at zero flow in a small air volume, the heat produced by the R_p winding begins to affect the R_{tc} winding.
- Step 5. Starting with the maximum flow rate, execute Steps 1 through 5 in Subsection 3.2, Part B.
- Step 6. While still measuring the nonlinear voltage at TB1-4, adjust the R21 up or down until you get a reading of 5.000 Vdc at specified maximum flow rate. (Note: Record this value for calibration point 11 in the "Actual Nonlin. Vdc" column.
- Step 7. For calibration points 1 through 10, repeat step 5. Remember to record the value for each calibration point in the "Actual Nonlin. Vdc" column.

3.4.3 Verifying the Nonlinear Voltages

The nonlinear circuitry, if the "zero" and "span" control-potentiometers are adjusted properly in reference to the current-sense voltage signals at zero and specified maximum flow rate, should yield a nonlinear voltage reading approximate to those recorded in the "Actual Nonlin. Vdc" column.

Formula for calculating the nonlinear voltages, given the following:

X = Current-sense voltage signal at zero flow rate

Y = Current-sense voltage signal at maximum flow rate

Z = Specific current-sense voltage signal of a calibration point for calculating the nonlinear voltage

Whereas:

$$\text{Factor Constant} = \frac{Y - X}{5}$$

Thus:

$$\text{Nonlin. Vdc} = \frac{Z - X}{\text{Factor Constant}}$$

Example: Given the proper differential pressures to set up air velocities of 0 SFPM, 750 SFPM, and 1500 SFPM. The current-sense voltage signal measured between TB1-3 (GND) and TB1-9 (I RET) are the following: 0 SFPM is 0.900 Vdc, representing a zero flow rate; 1500 SFPM is 1.500 Vdc, representing a maximum flow rate; and 750 SFPM is 1.384 Vdc, indicating a representation of flow of exactly half of the maximum flow rate. Calculate the nonlinear voltage for the calibration point at 750 SFPM.

a) Given: $X = 0.900 \text{ Vdc}$; $Y = 1.500 \text{ Vdc}$; and $Z = 1.384 \text{ Vdc}$

b) $\text{Factor Constant} = \frac{1.500 - 0.900}{5} = 0.12$

c) Therefore, $\text{Nonlin. Vdc} = \frac{1.384 - 0.900}{0.12} = 4.033 \text{ Vdc}$

3.5 Graphing Data Points

3.5.1 Plotting the Nonlinear Voltages on a Graph

This procedure illustrates the graphic technique used to plot the nonlinear voltages recorded in the "Actual Nonlin. Vdc" column against the ideal voltages in the "Desired Lin. Vdc" column. The ideal voltages are plotted on the x-axis and the nonlinear voltages are plotted on the y-axis.

Example: Provided data representing the values of the variable quantities on the y-axis vs. the values of the constant quantities on the x-axis. The ideal voltages, across the horizontal axis, correspond to a linear 0.000 to 5.000 Vdc output, with the vertical axis corresponding to nonlinear 0.000 to 5.000 Vdc input. Figure 3.5-1 shows this data plotted on a graph. Figure 3.5-2 shows a curve through the data points with one continual slope, avoiding a straight point-to-point connection of data points.

X-Axis (Ideal Voltages) Y-Axis (Nonlinear Voltages)

0.000 Vdc	0.000 Vdc
0.250 Vdc	1.460 Vdc
0.500 Vdc	2.140 Vdc
1.000 Vdc	2.923 Vdc
1.500 Vdc	3.410 Vdc
2.000 Vdc	3.740 Vdc
2.500 Vdc	4.037 Vdc
3.000 Vdc	4.270 Vdc
3.500 Vdc	4.490 Vdc
4.000 Vdc	4.664 Vdc
4.500 Vdc	4.855 Vdc
5.000 Vdc	5.000 Vdc

Figure 3.5-1
Graph of Plotted Nonlinear Voltages vs. Ideal Voltages

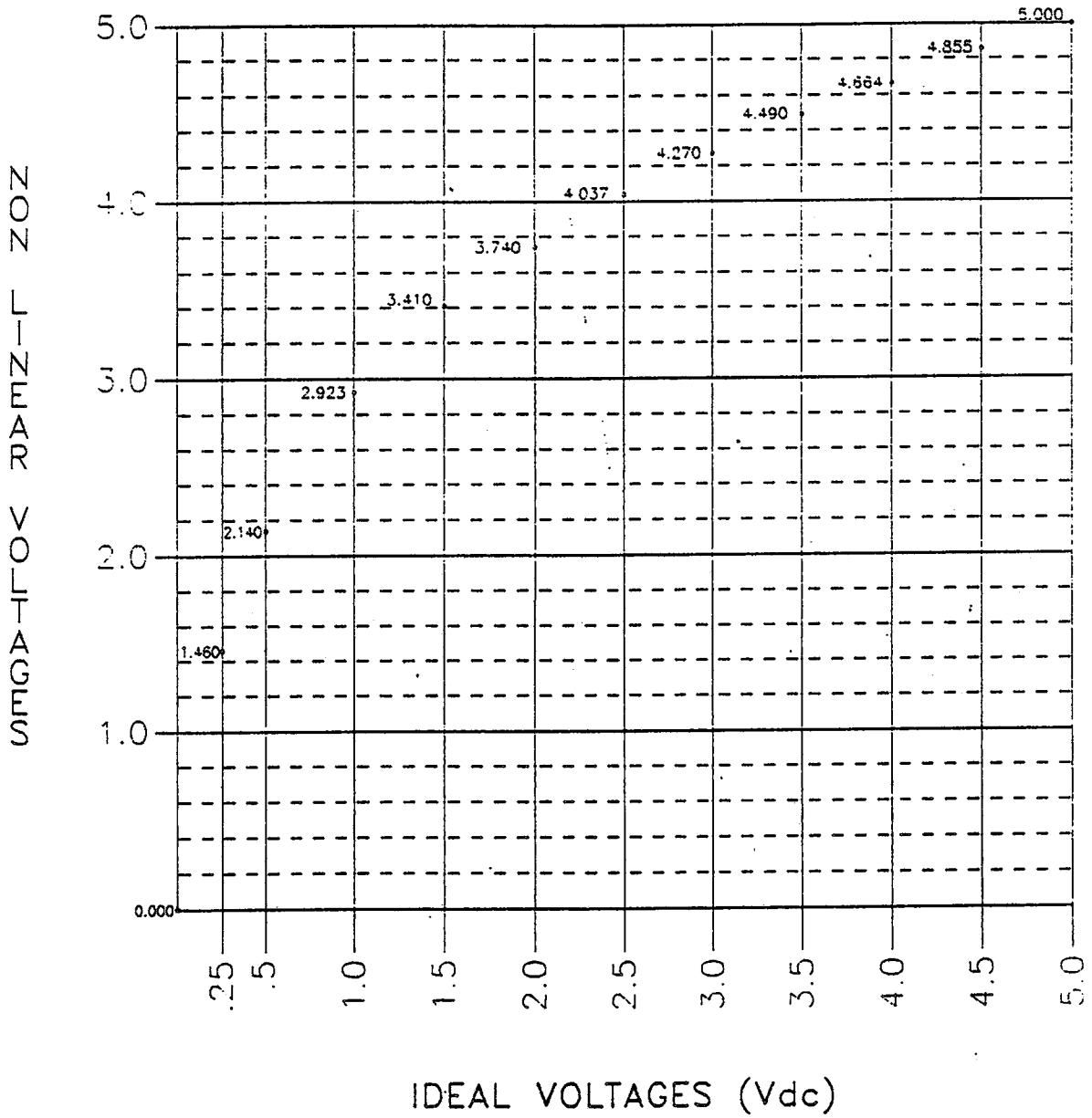
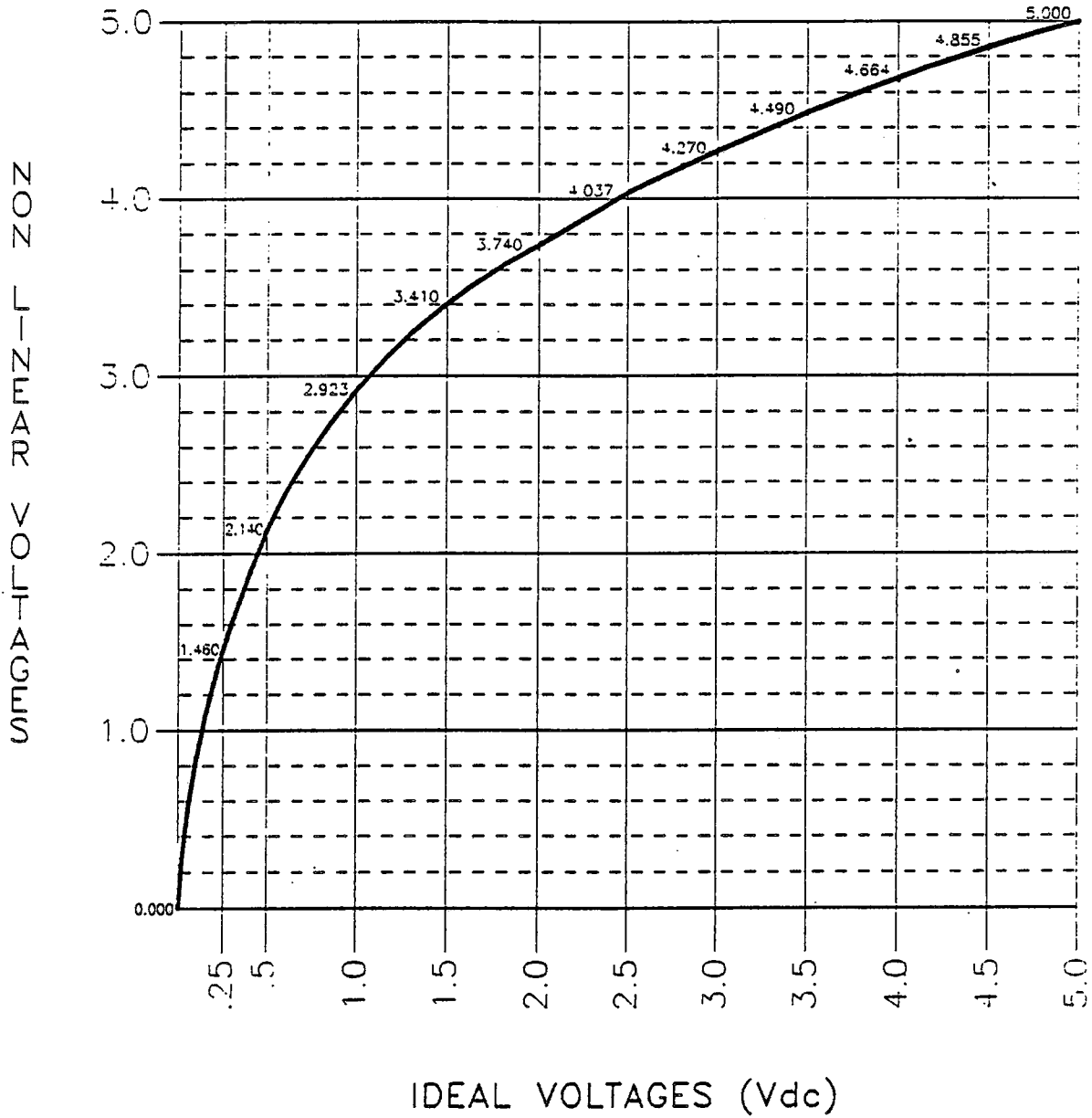

Figure 3.5-2
Curve for Plotted Nonlinear Voltages vs. Ideal Voltages



3.5.2 Plotting Break-Point Voltages on the Curve

- Step 1. Identify on the curve the break-point voltages listed in the "Break-Points" column.
- Step 2. Draw a horizontal line from each break-point voltage on the curve to the base line of the y-axis. From each break-point voltage on the same curve, draw a vertical line down to the base line of the x-axis.
- Step 3. The data extracted from the x-axis represents data points that will be used in linearizing the nonlinear 0.000 to 5.000 Vdc input signal to a linear 0.000 to 5.000 Vdc output signal. Record the obtained data for calibration points 0 to 11 in the "Linear Vdc Points" column.

For example, the curve now has the linearized "ideal voltages" from each of the break-point voltages as shown in Figures 3.5-3.

Figure 3.5-3
 Linear Voltage Points on the Curve

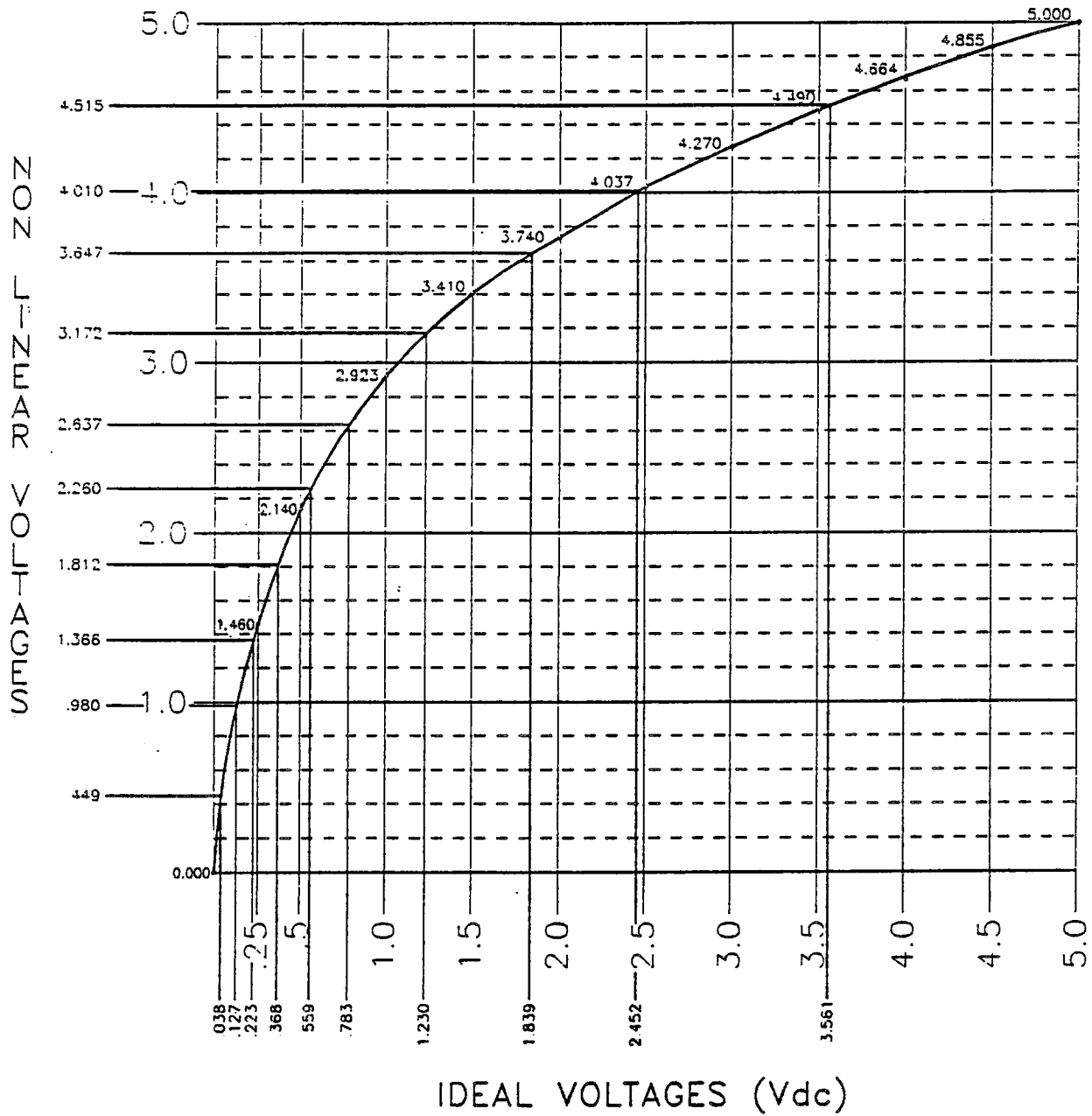

3.6 Adjustments to the Linear Circuitry

3.6.1 Calibrating the Linear Circuitry

This procedure primarily consists of inputting each break-point voltage listed in the "Break-Points" column to the linear circuitry of the linearizer board, and adjusting the appropriate control-potentiometer for each data point recorded in the "Lin. Vdc Points" column, respectively.

Note: A calibrated digital voltmeter (DVM) accurate to within ± 0.001 Vdc must be connected between terminal block 1, terminal screw 2 (TB1-2; LIN. OUT) and terminal block 1, terminal screw 3 (TB1-3; GND), and a variable power supply capable of up to 5.000 Vdc connected to test point 9 (TP9) and TB1-3 (GND).

- Step 1. As a precaution, before supplying input power to the linearizer board, we recommend the two-wire conductor cable be disconnected from the linearizer board to prevent any damages that may be incurred to the sensor and its associated circuitry during this calibration procedure.

- Step 2. Pull out jumper E₁₂ from the linearizer board. Removing jumper E₁₂ isolates the actual nonlinear signal that would be transmitted to the linear section in normal operations when the Kurz air flow meter is operational. Refer to Figure 3.6-1 for a simplified component diagram of the linearizer board. (**Note:** You will be adjusting the control-potentiometers shown within the dotted lines; i.e., by working clockwise starting from R₆₂, R₆₃, R₇₅...R₆₈.)

Figure 3.6-1
Simplified Component Diagram of the Linearizer Board

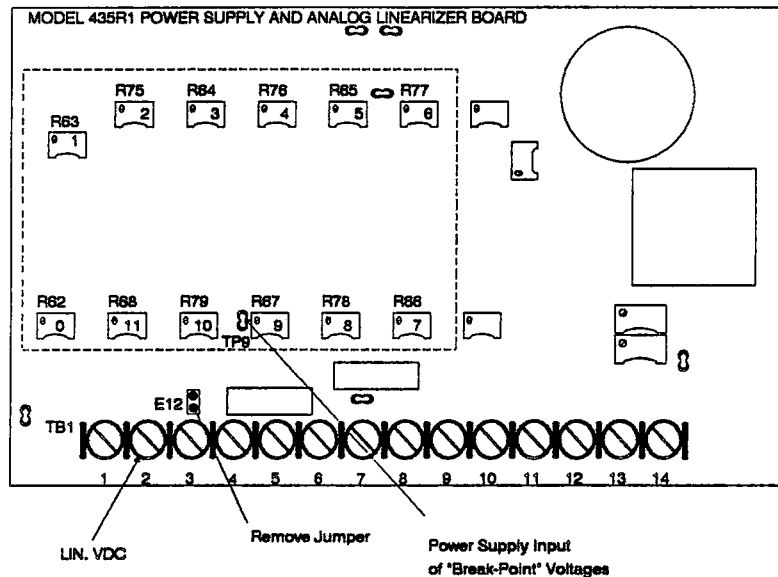

- Step 3. With an input of 0.000 Vdc at TP9, adjust R62 for a measurement of 0.000 Vdc output at TB1-2.
- Step 4. Supply an input of 0.449 Vdc at TP9. While monitoring the linear voltage output at TB1-2, adjust R63 for a voltage measurement of the equivalence recorded for calibration point 1 in the "Lin. Vdc Points" column.
- Step 5. Supply an input of 0.980 Vdc at TP9. While monitoring the linear voltage output at TB1-2, adjust R75 for a voltage measurement of the equivalence recorded for calibration point 2 in the "Lin. Vdc Points" column.
- Step 6. Supply an input of 1.366 Vdc at TP9. While monitoring the linear voltage output at TB1-2, adjust R64 for a voltage measurement of the equivalence recorded for calibration point 3 in the "Lin. Vdc Points" column.
- Step 7. Supply an input of 1.812 Vdc at TP9. While monitoring the linear voltage output at TB1-2, adjust R76 for a voltage measurement of the equivalence recorded for calibration point 4 in the "Lin. Vdc Points" column.

- Step 8. Supply an input of 2.260 Vdc at TP9. While monitoring the linear voltage output at TB1-2, adjust R65 for a voltage measurement of the equivalence recorded for calibration point 5 in the "Lin. Vdc Points" column.
- Step 9. Supply an input of 2.637 Vdc at TP9. While monitoring the linear voltage output at TB1-2, adjust R77 for a voltage measurement of the equivalence recorded for calibration point 6 in the "Lin. Vdc Points" column.
- Step 10. Supply an input of 3.172 Vdc at TP9. While monitoring the linear voltage output at TB1-2, adjust R66 for a voltage measurement of the equivalence recorded for calibration point 7 in the "Lin. Vdc Points" column.
- Step 11. Supply an input of 3.647 Vdc at TP9. While monitoring the linear voltage output at TB1-2, adjust R78 for a voltage measurement of the equivalence recorded for calibration point 8 in the "Lin. Vdc Points" column.
- Step 12. Supply an input of 4.010 Vdc at TP9. While monitoring the linear voltage output at TB1-2, adjust R67 for a voltage measurement of the equivalence recorded for calibration point 9 in the "Lin. Vdc Points" column.
- Step 13. Supply an input of 4.515 Vdc at TP9. While monitoring the linear Vdc output at TB1-2, adjust R79 for a voltage measurement of the equivalence recorded for calibration point 10 in the "Lin. Vdc Points" column.
- Step 14. Supply an input of 5.000 Vdc at TP9. While monitoring the linear voltage output at TB1-2, adjust R68 for a voltage measurement of the equivalence recorded for calibration point 11 in the "Lin. Vdc Points" column.

3.6.2 Verifying the Linear Voltages

The linear circuitry, if the procedures for calibration have been performed properly, should yield $\pm 2.0\%$ of reading plus 0.5% of full scale.

Formula for calculating the maximum value for the specified ideal voltage, given the following $\pm 2.0\%$ of reading plus 0.5% of full scale:

$$MPE_{lin. vdc} = (E \times 1.020) + 0.025$$

Formula for calculating the minimum value for the specified ideal voltage, given the following $\pm 2.0\%$ of reading plus 0.5% of full scale:

$$MPE_{lin. vdc} = (E \times 0.980) - 0.025$$

where,

$MPE_{lin. vdc}$ = the maximum percentage of error for the actual linear voltage to be in range

E = the ideal voltage in the "Desired Lin. Vdc" column

1.020 = maximum for 2.0% of reading

0.970 = minimum for 2.0% of reading

± 0.025 = 0.5% of full scale @ 5.000 Vdc

The procedure for checking the accuracy of the linear circuitry is similar to the preceding calibration procedure; except, instead of inputting the break-point voltages at TP9, you will be simulating each nonlinear voltage recorded in the "Actual Nonlin. Vdc" column. Nonetheless, you will still monitor the linear voltage outputs at TB1-2 with a DVM and record the voltage measurements in the "Actual Lin. Vdc" column for each simulated nonlinear voltage input.

- Step 1. With an input of 0.000 Vdc at TP9, monitor the linear voltage output at TB1-2. Record the voltage measurement for calibration point 0 in the "Actual Lin. Vdc" column. The voltage should be no more than 0.025 Vdc.

Step 2. Supply an input voltage at TP9 of the equivalence to the voltage recorded for calibration point 1 in the "Actual Nonlin. Vdc" column. Monitor the linear voltage output at TB1-2 and record the voltage measurement for calibration point 1 in the "Actual Lin. Vdc" column.

In comparison to the ideal voltage of 0.250 Vdc @ $\pm 2.0\%$ of reading plus 0.5% of full scale, the linear voltage output measured at TB1-2 should be no more than 0.280 Vdc or less than 0.220 Vdc.

Step 3. Supply an input voltage at TP9 of the equivalence to the voltage recorded for calibration point 2 in the "Actual Nonlin. Vdc" column. Monitor the linear voltage output at TB1-2 and record the voltage measurement for calibration point 2 in the "Actual Lin. Vdc" column.

In comparison to the ideal voltage of 0.500 Vdc @ $\pm 2.0\%$ of reading plus 0.5% of full scale, the linear voltage output measured at TB1-2 should be no more than 0.535 Vdc or less than 0.465 Vdc.

Step 4. Supply an input voltage at TP9 of the equivalence to the voltage recorded for calibration point 3 in the "Actual Nonlin. Vdc" column. Monitor the linear voltage output at TB1-2 and record the voltage measurement for calibration point 3 in the "Actual Lin. Vdc" column.

In comparison to the ideal voltage of 1.000 Vdc @ $\pm 2.0\%$ of reading plus 0.5% of full scale, the linear voltage output measured at TB1-2 should be no more than 1.045 Vdc or less than 0.955 Vdc.

Step 5. Supply an input voltage at TP9 of the equivalence to the voltage recorded for calibration point 4 in the "Actual Nonlin. Vdc" column. Monitor the linear voltage output at TB1-2 and record the voltage measurement for calibration point 4 in the "Actual Lin. Vdc" column.

In comparison to the ideal voltage of 1.500 Vdc @ $\pm 2.0\%$ of reading plus 0.5% of full scale, the linear voltage output measured at TB1-2 should be no more than 1.555 Vdc or less than 1.455 Vdc.

Step 6. Supply an input voltage at TP9 of the equivalence to the voltage recorded for calibration point 5 in the "Actual Nonlin. Vdc" column. Monitor the linear voltage output at TB1-2 and record the voltage measurement for calibration point 5 in the "Actual Lin. Vdc" column.

In comparison to the ideal voltage of 2.000 Vdc @ $\pm 2.0\%$ of reading plus 0.5% of full scale, the linear voltage output measured at TB1-2 should be no more than 2.065 Vdc or less than 1.935 Vdc.

Step 7. Supply an input voltage at TP9 of the equivalence to the voltage recorded for calibration point 6 in the "Actual Nonlin. Vdc" column. Monitor the linear voltage output at TB1-2 and record the voltage measurement for calibration point 6 in the "Actual Lin. Vdc" column.

In comparison to the ideal voltage of 2.500 Vdc @ $\pm 2.0\%$ of reading plus 0.5% of full scale, the linear voltage output measured at TB1-2 should be no more than 2.575 Vdc or less than 2.425 Vdc.

Step 8. Supply an input voltage at TP9 of the equivalence to the voltage recorded for calibration point 7 in the "Actual Nonlin. Vdc" column. Monitor the linear voltage output at TB1-2 and record the voltage measurement for calibration point 7 in the "Actual Lin. Vdc" column.

In comparison to the ideal voltage of 3.000 Vdc @ $\pm 2.0\%$ of reading plus 0.5% of full scale, the linear voltage output measured at TB1-2 should be no more than 3.085 Vdc or less than 2.915 Vdc.

Step 9: Supply an input voltage at TP9 of the equivalence to the voltage recorded for calibration point 8 in the "Actual Nonlin. Vdc" column. Monitor the linear voltage output at TB1-2 and record the voltage measurement for calibration point 8 in the "Actual Lin. Vdc" column.

In comparison to the ideal voltage of 3.500 Vdc @ $\pm 2.0\%$ of reading plus 0.5% of full scale, the linear voltage output measured at TB1-2 should be no more than 3.595 Vdc or less than 3.405 Vdc.

Step 10: Supply an input voltage at TP9 of the equivalence to the voltage recorded for calibration point 9 in the "Actual Nonlin. Vdc" column. Monitor the linear voltage output at TB1-2 and record the voltage measurement for calibration point 9 in the "Actual Lin. Vdc" column.

In comparison to the ideal voltage of 4.000 Vdc @ $\pm 2.0\%$ of reading plus 0.5% of full scale, the linear voltage output measured at TB1-2 should be no more than 4.105 Vdc or less than 3.895 Vdc.

Step 11: Supply an input voltage at TP9 of the equivalence to the voltage recorded for calibration point 10 in the "Actual Nonlin. Vdc" column. Monitor the linear voltage output at TB1-2 and record the voltage measurement for calibration point 10 in the "Actual Lin. Vdc" column.

In comparison to the ideal voltage of 4.500 Vdc @ $\pm 2.0\%$ of reading plus 0.5% of full scale, the linear voltage output measured at TB1-2 should be no more than 4.615 Vdc or less than 4.385 Vdc.

Step 12: Supply an input voltage at TP9 of the equivalence to the voltage recorded for calibration point 11 in the "Actual Nonlin. Vdc" column. Monitor the linear voltage output at TB1-2 and record the voltage measurement for calibration point 11 in the "Actual Lin. Vdc" column.

In comparison to the ideal voltage of 5.000 Vdc @ $\pm 2.0\%$ of reading plus 0.5% of full scale, the linear voltage output measured at TB1-2 should be no more than 5.125 Vdc or less than 4.875 Vdc.

Step 13. Install jumper E12. Hookup the two-wire conductor cable to terminal block 1, terminal screw 9 (TB1-9; I RET) and terminal screw 10 (TB1-10; 24.000 Vdc; RTC).

Note: If the linear voltage outputs are in specifications ($\pm 2.0\%$ of reading plus 0.5% of full scale), no further adjustments are needed, and the Kurz air flow meter is ready for process applications. If the linear voltages outputs are not within the specifications, then erroneous data exists in flow setup or graphing and the procedures for calibration should be reviewed.

3.6.3 Adjustments to the Optional Signal Output

The linearizer board can also provide a second linear 0.000 to 5.000 Vdc analog output located at terminal block 1, terminal screw 1 (TB1-1; ENG. UNIT SIG. OUT) or when external devices are used, we call terminal block 3, terminal screw 1 (TB3-1).

This procedure simply consists of inputting 5.000 Vdc representing a selected velocity calibration range at TP9 and adjusting R99 (control-potentiometer) to read 5.000 Vdc at TB1-1. In some cases, you will need to simulate a specified scaled voltage representing mass flow rate for a specified duct or pipe area.

Note: A calibrated digital voltmeter (DVM) accurate to within ± 0.001 Vdc must be connected between TB1-1 and TB1-3 (GND) and a variable power supply capable of up to 5.000 Vdc connected to TP9 and TB1-3 (GND).

KURZ CALIBRATION WORK SHEET

KURZ MODEL: 450-08-AT-LD-6"

CUSTOMER CODE: AIR-FLO

	FLOW RATE		IDEAL LIN. VDC	ACTUAL LIN. VDC	ACTUAL mA OUT	ACTUAL NONLIN. VDC	INCHES OF H2O	CURRENT SENSE D.C. VDC		BREAK POINTS	LIN. VDC POINTS
	VELOCITY POINT	MASS POINT									
0	0		0.000	0.000		0.000	0	0.900	0	0.000	0.000
1	75		0.250	0.255		1.460	0.093	1.075	1	0.449	0.038
2	150		0.500	0.507		2.140	0.185	1.157	2	0.980	0.127
3	300		1.000	1.003		2.923	0.310	1.251	3	1.366	0.223
4	450		1.500	1.529		3.410	0.470	1.309	4	1.812	0.368
5	600		2.000	2.005		3.740	0.650	1.349	5	2.260	0.559
6	750		2.500	2.523		4.037	0.780	1.384	6	2.637	0.783
7	900		3.000	3.041		4.270	1.045	1.412	7	3.172	1.230
8	1050		3.500	3.534		4.490	1.180	1.439	8	3.647	1.839
9	1200		4.000	4.000		4.664	1.250	1.460	9	4.010	2.452
10	1350		4.500	4.562		4.855	1.530	1.483	10	4.515	3.561
11	1500		5.000	5.000		5.000	1.720	1.500	11	5.000	5.000

LFE S/N: 104180-T4-R5
 LFE Area: 0.057609501 FT²
 Model No.: 400B
 DVM S/N: 2092
 Temp. S/N: 13001
 Bar. S/N: 11508 Y1
 Pipe Size: NA
 Pipe Area: NA

Due Date: 01 JUL 92
 Due Date: 05 MAR 92
 Due Date: 28 MAR 92
 Due Date: NA

Range: 0 - 1500 SFPM
 Input: 115 Vac 60 Hz
 Vdc
 I-Mode: Yes X No
 Absolute Pressure: 29.00 "Hg
 Actual Temperature: 90 °F
 Calculated Nonlin. Resistors:
 R₁₇ 54.55 KΩ R₂₃ 74.55 KΩ

COMMENTS:

BRIDGE VOLTAGE
 Zero Flow: 2.919 Vdc
 Max. Flow: 8.452 Vdc
For Intrinsic Safety Circuit:
 Zener Diode: NA
 Ballast Resistor: NA

CURRENT-SENSE VOLTAGE
 Zero Flow: 0.900 Vdc
 Max. Flow: 1.500 Vdc

Technician: THOMAS KOBAYASHI, JR.

Date: 24 APR 91

End of Section 3



Section 4: Maintenance and Trouble-Shooting

4.1 Maintenance

The Kurz air flow meters are virtually maintenance free. Though, when required, we recommend the following:

- Electronics maintenance
- Sensor maintenance

CAUTION: When dismantling the system for repair, recalibration and, or cleaning make sure that power is off.

4.1.1 Electronics Maintenance

The transmitter enclosures; and the electronic components on the current-transmitter board and linearizer board essentially require no maintenance; however, should be periodically inspected and cleaned.

The factory calibration of the system remains stable over a duration of up to several years. However, in order to sustain NIST-traceability¹, annual recalibrations are recommended.

Note: If the system requires recalibration while still under warranty, contact Kurz Instruments, Inc. at (800) 424-7356 and ask for Customer Service.

¹ National Institute of Standards & Technology. Provided with each system is a Calibration Data and Certification Document.

4.1.2 Sensor Maintenance

Sensor maintenance comprises of inspecting the sensor flow path and checking the sensor for proper functioning.

The Kurz thermal mass flow sensor render it resistant to particulate contamination in most applications; nevertheless, performs best when it is kept relatively free of contamination. You should, therefore, check the sensor at regular intervals, cleaning it if necessary. Be careful not to damage the sensor during removal or reinsertion. A bent sensor may develop a short and would need to be replaced.

a) For a Kurz MetalClad™ sensor, use a fine wire brush, crocus cloth or fine grit emery cloth to remove build-up contamination from the sensor.

Note: Some sensors may have small specks of excess metal adhering to their sheaths. This is normal and in no way degrades the performance of the sensors. Do NOT attempt to remove such specks. Doing so may change the sensor's *temp comp* calibration.

b) For a Kurz DuraFlo™ sensor, use a small camel's hair brush and water, followed by an alcohol rinse.

4.2 Trouble-Shooting

This procedure to help locate the section of the electronic assembly at fault. It is not intended to be an all inclusive repair manual. Nonetheless, the corrective actions to be taken usually recommend electronic components or wiring connections to be corrected, replaced or repaired by a certified electrical technician, familiar with electronic test equipment and measurements. In most major repairs, the unit should be returned to the Kurz factory for service. Kurz Instruments, Inc. will provide technical assistance over the phone to qualified repair personnel. Please call Customer Service Department (800) 424-7356.

Once installed, the operation of the Kurz air flow meter is primarily a matter of maintaining power to the system. The system will continue to operate for prolonged periods without intervention. However, when it is suspected that the system is not operating correctly, there are a few simple test procedures that can be checked or performed before dismantling for repair:

- Power-on voltage test for the Model 435R₁ Power Supply and Analog Linearizer Board
- Power-on voltage test for the Model 465R_x Current-Transmitter Board

WARNING: Any warranty service to be performed at the customer's site must have written authorization by Kurz Instrument's Inc. Nonwarranty service should be performed only by a certified electrical technician.

4.2.1 Test Procedure for the Model 435R₁ Power Supply and Analog Linearizer Board

The test procedure for the linearizer board consists of verifying voltages between terminal block 1, terminal screw 3 (TB1-3; GND) and each of the nine test points given. Refer to Figure 4.2-1 for the location of the test points on the linearizer board. You will need a digital voltmeter (DVM) accurate to within ± 0.001 Vdc.

Figure 4.2-1.
Test Points on the Linearizer Board

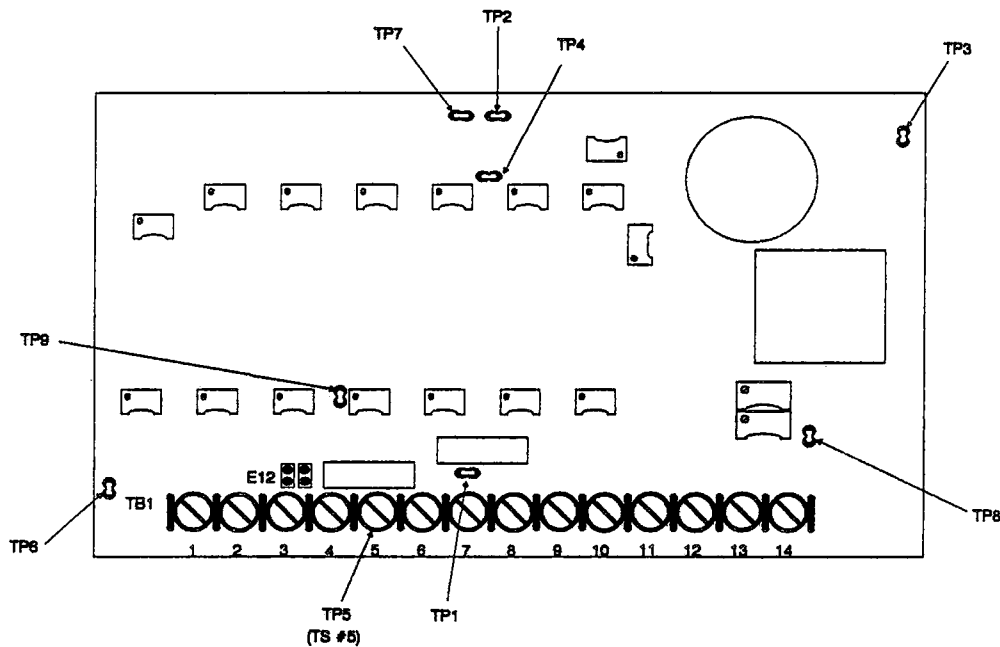

Note: All test verifications with the exception of test points 1 and 9 can be checked with the two-wire loop operation disconnected from the linearizer board. This allows the removal of the linearizer board from the system enclosure for bench-test purposes. However, a power source must be connected to the AC terminals on terminal block 1, terminal screws 12 (TB1-12; AC GND), 13 (TB1-13; ACC) and 14 (TB1-14; AC).

The power-on voltage test for the linearizer board are as follows:

Test point 1 (TP1) — is for the current-sense voltage (flow meter must be operational) of 0.600 Vdc, ± 0.015 Vdc at zero flow rate to 3.000 Vdc, ± 0.075 Vdc at specified maximum flow rate (this voltage is nominal, refer to the appropriate Calibration Data and Certification Document for exact rated voltage).

Test point 2 (TP2) — is for the unregulated supply voltage of 24.000 Vdc, ± 5.000 Vdc.

Test point 3 (TP3) — is for the unregulated, negative supply voltage of -24.000 Vdc, ± 5.000 Vdc.

Test point 4 (TP4) — is for the regulated supply voltage of 15.000 Vdc, ± 0.450 Vdc.

Test point 5 (TP5) or TB1-5 — is for the regulated, negative supply voltage of -12.000 Vdc, ± 0.360 Vdc.

Test point 6 (TP6) — is for the regulated supply voltage of 5.000 Vdc, ± 0.150 Vdc.

Test point 7 (TP7) — is for the reference voltage of 2.490 Vdc, ± 0.001 Vdc.

Test point 8 (TP8) — is for the negative reference voltage of -5.000 Vdc, ± 0.001 Vdc.

Test point 9 (TP9) — is for the nonlinear voltage signal to the linearizing circuitry (flow meter must be operational): 0.000 Vdc, 0.025 Vdc at zero flow rate and 5.000 Vdc, ± 0.125 Vdc at specified maximum flow rate.

Note: Refer to Appendix B: *Trouble-Shooting Guide*, for more indepth information pertaining to the symptoms and probable causes for electronics malfunction on the linearizer board.

4.2.2 Testing the Model 465R_x Current-Transmitter Board

This test procedure allows you to verify the operation of the Model 465R₆ and 465R₇ Current-Transmitter Boards. You will need a digital voltmeter (DVM) accurate to within ± 0.001 Vdc.

Before you perform the test, check to make sure that the following conditions are met:

- a) The two-wire conductor cable is properly connected to terminal block 1 (TB1) on both the current-transmitter board and linearizer board.
- b) The four-wire or five-wire cable from the sensor is properly connected to the appropriate terminal screws on terminal block 2 (TB2) on the current-transmitter board. (Note: For a probe assembly with a "TS" electronic configuration, make sure the wiring from the terminal board in the junction box are properly connected to TB2 on the current-transmitter board.)
- c) If possible, set the flow to zero flow rate.

Note: All test point are accessible on the current-transmitter board after the cover of the flow transmitter enclosure has been removed. Refer to Figures 4.2-2 and 3.2-3, respectively, for the test point locations where the voltages and current can be measured.

Figure 4.2-2.
Model 465R6 Current-Transmitter Board

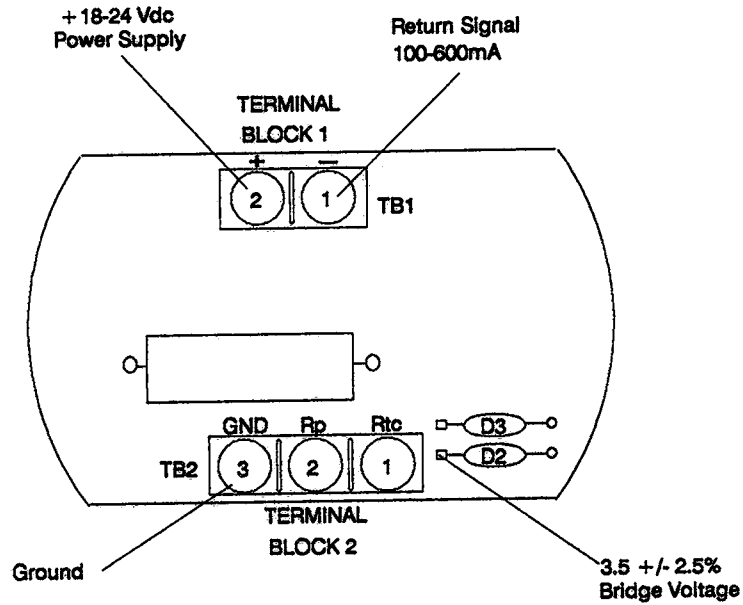
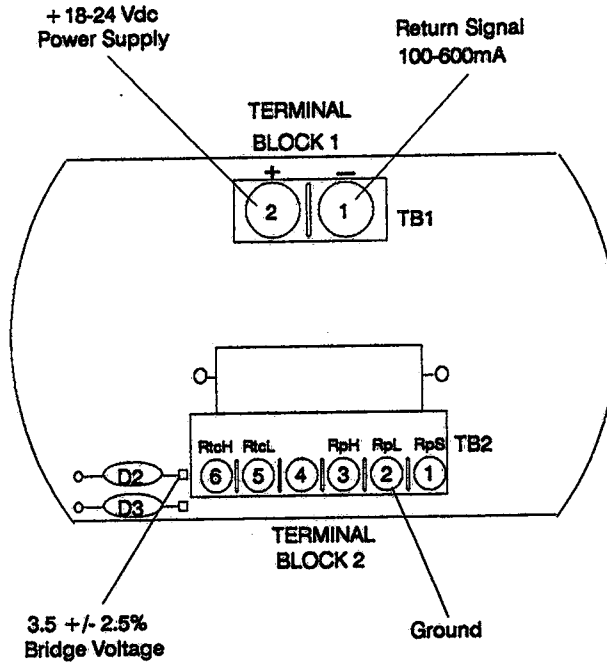

Figure 4.2-3
Model 465R7 Current-Transmitter Board



A. Power-On Voltage Test for the Model 465R₆ Current-Transmitter Board

- Step 1. Check the 24.000 Vdc input voltage. The two-wire conductor cable should be connected to terminal block 1, terminal screws 1 (TB1-1) and 2 (TB1-2). The 24.000 Vdc power source should be connected to terminal screw 2 and the return signal should be connected to terminal screw 1. With the power supply turned off, make sure these connections are secure.

With the power turned on, check the voltage between terminal block 2, terminal screw 3 (TB2-3; GND) and TB1-2 (24.000 Vdc).

- Step 2. Check the bridge voltage (B.V.). The B.V. will vary with the air flow. As the velocity increases, the amount of power required to maintain the standard overheat increases. To verify the sensor and bridge circuit are operating this way, measure the voltage between TB2-3 (GND) and the leg of diode D₂ closest to TB2. This voltage should range from 3.500 Vdc to 9.000 Vdc, typically.

- Step 3. Check the current-return signal. The current-return signal will also vary with the air flow. As the velocity increases, the amount of power required to maintain the standard overheat increases.

Measure the amount of current being transmitted from the current-transmitter board to the linearizer by placing an ammeter in series with TB1-1 (I RET) and the conductor cable. The current measured should be in the 100 to 600 mA range, dependent on the amount of air flow measured by the sensor.

B. Power-On Voltage Test for the Model 465R7 Current-Transmitter Board

Step 1. Check the 24.000 Vdc input voltage. The two-wire conductor cable should be connected to terminal block 1, terminal screws 1 (TB1-1) and 2 (TB1-2). The 24.000 Vdc power source should be connected to terminal screw 2 and the return signal should be connected to terminal screw 1. With the power supply turned off, make sure these connections are secure.

With the power turned on, check the voltage between terminal block 2, terminal screw 2 (TB2-2; GND/R_{pL}) and TB1-2 (24.000 Vdc).

Step 2. Check the bridge voltage (B.V.). The B.V. will vary with the air flow. As the velocity increases, the amount of power required to maintain the standard overheat increases. To verify the sensor and bridge circuit are operating this way, measure the voltage between TB2-2 (GND/R_{pL}) and the leg of diode D2 closest to TB2. This voltage should range from 3.500 Vdc to 9.000 Vdc, typically.

Step 3. Check the current-return signal. The current-return signal will also vary with the air flow. As the velocity increases, the amount of power required to maintain the standard overheat increases.

Measure the amount of current being transmitted from the current-transmitter board to the linearizer board by placing an ammeter in series with TB1-1 (I RET) and the conductor cable. The current measured should be in the 100 to 600 mA range, dependent on the amount of air flow measured by the sensor.

C. RTD Windings Resistance Verification

If the sensor appears to be at fault, it can be tested and verified by measuring the ohmage of the RTD windings².

With the power supply turned off, remove the four-wire or five-wire conductor cable from the terminal screws of terminal block 2 (TB2) on the current-transmitter board. Refer to Tables 4.2-1, 4.2-2 and 4.2-3 for the RTD winding resistance verification procedures.

CAUTION: If the sensor's wires are removed be certain to hook them up as wired by the Kurz factory.

Table 4.2-1
RTD Winding Test Procedure

RESISTANCE VERIFICATION CHART			
Sensor Type	Velocity Sensor		Ohmage @ Amb. Temp. 25° C
	Four-wire	Five-wire	
"dual-sting"	$R_{tcGND} \& R_{tc}$	$R_{tcL} \& R_{tcH}$	329 ohms \pm 1.0%*
	$R_{pGND} \& R_p$	$R_{pS}, R_{pL} \& R_{pH}$	10 ohms \pm 1.0%

* Refers to resistance for a large "dual-sting" (LD) sensor; whereas, the resistance for a miniature "dual-sting" (MD) sensor is 110 ohms \pm 1.0%.

² Values obtained that are substantially different indicate a damaged sensor.

Table 4.2-2
RTD Winding Test Procedure

RESISTANCE VERIFICATION CHART			
Sensor Type	Velocity Sensor		Ohmage @ Amb. Temp. 25° C
	Four-wire	Five-wire	
"single-sting"	R _{tcGND} & R _{tc}	R _{tcL} & R _{tcH}	164 ohms ± 1.0%
	R _{pGND} & R _p	R _{pS} , R _{pL} & R _{pH}	20 ohms ± 1.0%*

* Refers to the resistance for a DuraFlo™ sensor; whereas, the resistance for a MetalClad™ sensor is 10 ohms ± 1.0%.

Table 4.2-3
RTD Winding Test Procedure

RESISTANCE VERIFICATION CHART			
Sensor Type	Velocity Sensor	Temp. Sensor	Ohmage @ Amb. Temp. 25° C
	Four-wire	Two-wire	
"triple-sting"	R _{tcGND} & R _{tc}		164 ohms ± 1.0%
	R _{pGND} & R _p		10 ohms ± 1.0%
		R _{tdGND} & R _{td}	110 ohms ± 1.0%

End of Section 4



Appendix A: Engineering Drawings

The appendix contains engineering drawings of the electronic assemblies associated with the Kurz air flow meter. A blank Kurz calibration work sheet is also included for your convenience. You are free to copy it for calibration purposes.

Note: If you want to perform your own warranty service, you must first obtain written authorization from Kurz Instruments, Inc. **Unauthorized service performed during the warranty period voids your warranty.** Please read the warranty statement at the front portion of this manual before performing any services.

DWG. No.	Description
420019	PCB, ASS'Y., 435R ₁
340055	Series 455/555/505 System Wiring Diagram
420160	PCB, ASS'Y., 465R ₇
340281	Wiring Diagram, 465R ₇ & 5-Wire Sensor
420158	PCB, ASS'Y., 465R ₆
340282	Wiring Diagram from J-Box to Electronic Enclosure



NOTES: UNLESS OTHERWISE SPECIFIED

- THIS DRAWING TO BE USED IN CONJUNCTION WITH SCHEMATIC DIAGRAM # 300013
- R5,8-10,D1-3 TO BE ASSEMBLED WITH 1/4" CLEARANCE FROM PC BOARD.
- FOR NON-LINEAR OPTIONS (-04, -05, -08, -09), DO NOT ASSEMBLE R25-106, D7-32, C18-22, U2-5.
- FOR HEATSINK TO TRANSISTOR ASSEMBLY SEE DWG. NO. A70003.
- MALLOY CAPACITOR TO BE USED FOR NUCLEAR UNITS ONLY, 3500uF, 40V.
- T1 CENTER TAP WIRE (STRIPPED) SOLDERED TO PAD INDICATED.
- INSTALL D2,3,R9,10 FOR SENSOR SAFETY CIRCUITS ONLY.
- FOR CURRENT SENSE VOLTAGE, MEASURE BETWEEN TBI-3 (GND) AND TBI-9 (CURRENT RETURN).

PART NO.	DESCRIPTION	CLOSE JUMPER
	HEAVY DUTY, CURRENT MODE, 220V	E5,7,8,9,12
	HEAVY DUTY VOLTAGE MODE, LIN.	E10, 12
-03	HEAVY DUTY, CURRENT MODE, LIN	E5,7,8,9,12
-04	HEAVY DUTY, VOLTAGE MODE, NON-LIN.	E10
-05	HEAVY DUTY, CURRENT MODE, NON-LIN.	E5,7,8,9
	VOLTAGE MODE DC, LIN.	E2,3,4,10,12
-07	CURRENT MODE, DC, LIN.	E2,3,4,5,7,8,9,12
	VOLTAGE MODE NON-LIN. DC	E2,3,4,10
	CURRENT MODE NON-LIN. DC	E2,3,4,5,7,8,9

REV.	DESCRIPTION	DATE	BY	CHKD.	DATE	BY	APPROVED	DATE
A	REVISED PER ECO'S A43547005 + A43547006. REF ECO A43547007	5-5-87	J. Careaga	J. Careaga	6-1-87	N/A	6/1/87	5-11-87
B	REVISED PER ECO A43547007	5-21-87	J. Careaga	J. Careaga	6-2-87	N/A	6/2/87	6-30-87
C	REVISED PER ECO A43547009 A43547010 AND A43547011	2-11-88	N. S. ...	N. S. ...	2-11-88	NA	2-11-88	2-11-88
D	REVISED PER ECO # A47214	9-6-88	B. ...	B. ...	9-6-88	N/A	9/6/88	9/6/88
E	REVISED PER ECO 47730	5-13-89	J. Careaga	J. Careaga	5-13-89	UA	5/13/89	5/13/89

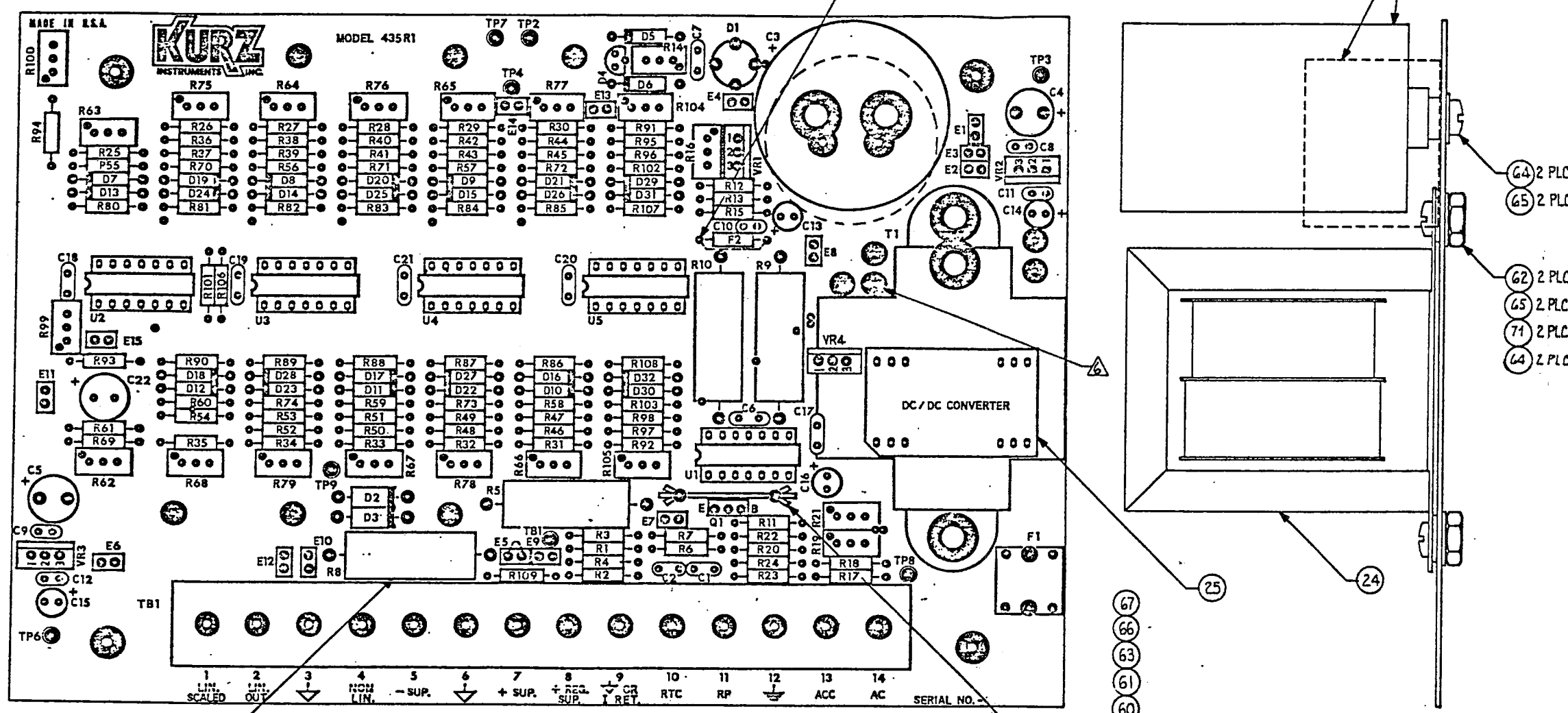

JUMPER	DESCRIPTION
E1	TIES COMMON GND AND CHASSIS GND - TO REMAIN OPEN.
E2,3,4	USE A DC/DC CONVERTER. DO NOT INSTALL T1, VR2, C4, 8.
E5,7,8,9	CURRENT MODE. DO NOT INSTALL C1, 2, 6, D2, 3, Q1, R1-7, 9, 10, 109.
E6	FOR 24 V FROM TBI-7.
E10	VOLTAGE MODE. INSTALL C1, 2, 6, D2, 3, Q1, R1-7, 9, 10, 109.
E11	FOR 15V FROM TBI-7.
E12	FOR LINEAR SECTION.
E13,14	OPTIONAL INVERTER OR BREAK POINT.
E15	ADJUST FOR X-5 VDC OUT.

71	2	WASHER, #10, NYLON.
70	A/R	SHUNT, 2 PIN
69	14	E2-4, 6-15
68	3	F2, E5
67	1	WASHER COMPRESSED
66	1	WASHER #4 STAR
65	4	WASHER #10 STAR
64	4	SCREW #10-32 X 1/4 PHIL PAN HEAD
63	1	SCREW #4-40 X 5/16 PHIL PAN HEAD
62	2	NUT #10-32
61	1	NUT #4-40
60	1	KOOLEX PAD
59	1	HEATSINK
58		

UNLESS OTHERWISE SPECIFIED DIMENSIONS ARE IN INCHES		APPROVALS	
TOLERANCES ARE	DESIGNED BY	DATE	
FRACTIONS ± 1/32	J. CAREAGA	6-30-86	
ANGLES ± 0°-20°	CHECKED BY	DATE	
DECIMALS ± 0.01	J.D. Young	2-2-87	
± 0.005	DATE		
± 0.002			
± 0.001			
DRG. RELEASE DATE	DATE		

KURZ INSTRUMENTS INC.		TITLE	
		PCB, ASSY., 435R1	
DWG. NO.	DWG. NO.	REV.	
D	420019		
SCALE	2:1	SHEET 1 OF 1	





REV	DATE	BY	DESCRIPTION	QTY	UNIT	PRICE	TOTAL
A	1962	WHE	AS PCB	100	PCB	1.75	175.00
B	1962	WHE	CHANGED PER ECD # 47151	100	PCB	1.75	175.00
C	1962	WHE	CHANGED PER ECD # 47153	100	PCB	1.75	175.00
D	1962	WHE	CHANGED PER ECD # 47146	100	PCB	1.75	175.00
E	1962	WHE	CHANGED PER ECD # 47154	100	PCB	1.75	175.00
F	1962	WHE	CHANGED PER ECD # 47150	100	PCB	1.75	175.00

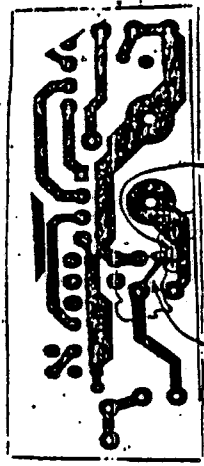

CUT TRACE
 AS PER JMWHEEL
 C MODIFICATION DETAIL
 SHOWN FROM JMWHEEL SHEET

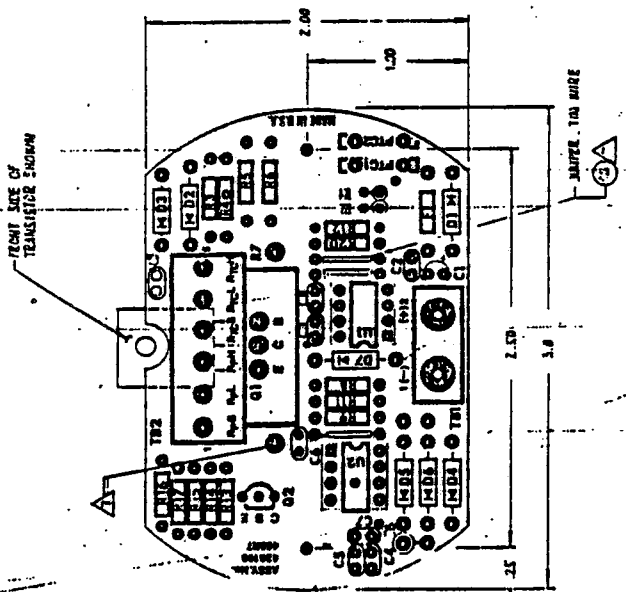

AT	HT	MT
RECEIVED	RECEIVED	RECEIVED
RECEIVED	RECEIVED	RECEIVED
RECEIVED	RECEIVED	RECEIVED
RECEIVED	RECEIVED	RECEIVED

ADD JMWHEEL, SHEET 01

NOTES
 1. THIS PCB TO BE USED IN CONNECTION WITH
 A SPECIFIC PROGRAM
 2. THIS PCB IS TO BE ASSEMBLED WITH
 A PCB TO BE ASSEMBLED WITH CARTRIDGE TO PCB
 FROM PCB
 3. THIS PCB IS TO BE ASSEMBLED WITH 1/4" DIA
 CARTRIDGE PER JMWHEEL SHEET 001

KURZ INSTRUMENTS INC.
 PCB, ASSY., 465RT
 470160

REV	DATE	BY	DESCRIPTION
A	1962	WHE	AS PCB
B	1962	WHE	CHANGED PER ECD # 47151
C	1962	WHE	CHANGED PER ECD # 47153
D	1962	WHE	CHANGED PER ECD # 47146
E	1962	WHE	CHANGED PER ECD # 47154
F	1962	WHE	CHANGED PER ECD # 47150





REV.	DESCRIPTION	DATE	BY	CHKD.	APP.
1	RELEASED TO PRODUCTION	02/11/73	WJG	WJG	WJG

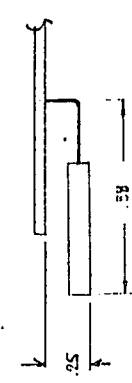
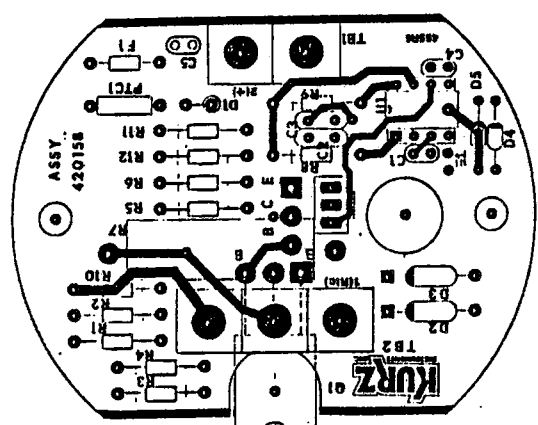

- NOTES: UNLESS OTHERWISE SPECIFIED
1. THIS DRAWING TO BE USED IN CONJUNCTION WITH SCHEMATIC DIAGRAM 300CS6.
 2. FINAL ASSY. AS REQUIRED BY KURZ.
 3. C1-C4 ARE OPTIONAL CERAMIC CAPACITORS. VALUE C1 = 10UF, 50V.
 4. RESISTOR R7 IS 5 WATTS, WIREWOUND SIX TOLERANCE LOW T.C.
 5. D1 TO BE ASSEMBLED W/ CATHODE TO PCB.
 6. R7, D2,3 TO BE ASSEMBLED W/ 1/4" x 1/16" FROM PCB.
 7. D4,5 ARE OPTIONAL FOR GAS CAL ONLY, CLOSE E1 FOR ALL STD. UNITS.

KURZ INSTRUMENTS INC.	
TITLE	PCB, ASSY., 465R8
DWG. NO.	420158
SCALE	C
SHEET	1

APPROVALS	
DESIGNED BY	WJG
CHECKED BY	WJG
DATE	02/11/73
APPROVED BY	WJG
DATE	02/11/73
SCALE	C
SHEET	1

1 2 3 4



KURZ INSTRUMENTS, INC. PROPRIETARY RIGHTS ARE PROTECTED BY PATENT AND COPYRIGHT LAWS. ALL RIGHTS RESERVED. THIS DOCUMENT IS UNCLASSIFIED EXCEPT AS SPECIFICALLY INDICATED OTHERWISE. KURZ INSTRUMENTS, INC. PROPRIETARY RIGHTS ARE PROTECTED BY PATENT AND COPYRIGHT LAWS. ALL RIGHTS RESERVED. THIS DOCUMENT IS UNCLASSIFIED EXCEPT AS SPECIFICALLY INDICATED OTHERWISE.

REVISIONS			
REV.	DESCRIPTION	DATE	APPROVED

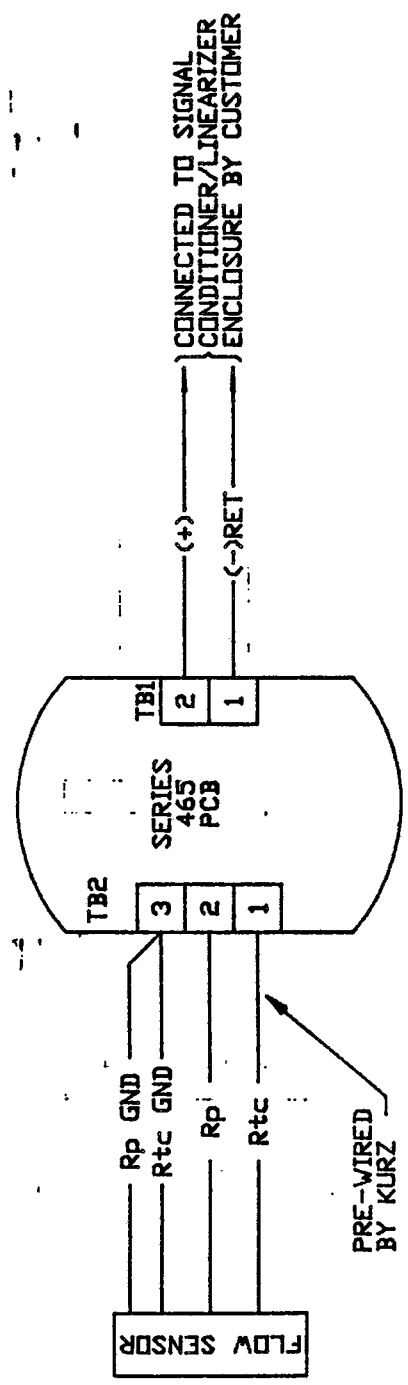

PRE-WIRED BY KURZ

NOTES:
 1. TWO WIRE CABLE, SHIELDED RECOMMENDED, PROVIDED AND CONNECTED BY CUSTOMER. FOR CABLE LENGTH FIGURE OUT FOR MAX. LOOP RESISTANCE OF 4 OHMS. HOWEVER, KURZ WILL PROVIDE 15 FT. OF TWO WIRE CABLE FOR TESTING PURPOSE.

KURZ INSTRUMENTS INC.	
TITLE	
WIRING DIAGRAM, FROM JUNCTION BOX TO ELECTRONIC ENCLOSURE	
DWG. NO.	340282
DWG. SIZE	B
SCALE	NONE
SHEET	1 OF 1

APPROVALS	
DATE	DATE
10-14-73	
CHECKED BY	DATE
DESIGN	DATE
APPROVED	DATE
BASELINED	DATE

UNLESS OTHERWISE SPECIFIED DIMENSIONS ARE IN INCHES
 TOLERANCES ARE
 FRACTIONS ± 1/32
 ANGLES ± 0° - 30'
 DECIMALS
 .1 ± .01
 .2 ± .02
 .3 ± .03
 .4 ± .04
 .5 ± .05
 .6 ± .06
 .7 ± .07
 .8 ± .08
 .9 ± .09
 1.0 ± .10
 DIM. RELEASE DATE



KURZ CALIBRATION WORK SHEET

KURZ MODEL: _____

CUSTOMER CODE: _____

	FLOW RATE		IDEAL LIN. VDC	ACTUAL LIN. VDC	ACTUAL mA OUT	ACTUAL NONLIN. VDC	INCHES OF H2O	CURRENT SENSE D.C. VDC	BREAK POINTS	LIN. VDC POINTS
	VELOCITY POINT	MASS POINT								
0			0.000						0	0.000
1			0.250						1	0.449
2			0.500						2	0.980
3			1.000						3	1.366
4			1.500						4	1.812
5			2.000						5	2.260
6			2.500						6	2.637
7			3.000						7	3.172
8			3.500						8	3.647
9			4.000						9	4.010
10			4.500						10	4.515
11			5.000						11	5.000

LFE S/N: _____
 LFE Area: _____
 Model No.: _____
 DVM S/N: _____
 Temp. S/N: _____
 Bar. S/N: _____
 Pipe Size: _____
 Pipe Area: _____

Due Date: _____
 Due Date: _____
 Due Date: _____

Range: _____

Input: _____ Vac _____ Hz
 _____ Vdc

I-Mode: Yes _____ No _____
 Absolute Pressure: _____ "Hg
 Actual Temperature: _____ °F
 Calculated Nonlin. Resistors:
 R17 _____ R23 _____

COMMENTS:

BRIDGE VOLTAGE

Zero Flow: _____
 Max. Flow: _____
For Intrinsic Safety Circuit:
 Zener Diode: _____
 Ballast Resistor: _____

CURRENT-SENSE VOLTAGE

Zero Flow: _____
 Max. Flow: _____

Technician: _____

Date: _____



Appendix B: Trouble-Shooting Guide

This appendix reviews trouble-shooting information for minor repairs should such problems occur during the calibration procedures and, or process applications. This guide is provided to help locate the section of the electronic assembly at fault. It is not intended to be an all inclusive repair manual. In most major repairs, the unit should be returned to the Kurz factory for service. Kurz Instruments, Inc. will provide technical assistance over the phone to qualified repair personnel. Please call Customer Service Department at our toll-free number 1-800-424-7356.

Do not return any equipment without a Return Material Authorization, obtainable from the Customer Service Department. Information describing the problem, corrective action or work to be accomplished at the Kurz factory, purchase order number the equipment was purchased under, and name of person to contact must be included with the return equipment.

Return shipping address:

KURZ INSTRUMENTS, INC.
2411 GARDEN ROAD
MONTEREY, CA 93940

ATTN: CUSTOMER SERVICE DEPT.

Note: Transportation charges for equipment shipped to the Kurz factory for warranty repair are to be paid by the shipper. We will return the equipment under warranty prepaid.



TROUBLE-SHOOTING GUIDE

*** Symptom:** No voltage at TP1.

Probable Cause: Kurz thermal mass flow sensor disconnected, Q1 (heat sink transistor) on current-transmitter board bad, no bridge voltage, no unregulated supply voltage of 24.000 Vdc getting to the current-transmitter board, faulty two-wire loop connection between current-transmitter board and linearizer board or R8 (resistor) open.

*** Symptom:** No voltage at TP2.

Probable Cause: T₁ (transformer), D₁ (bridge rectifier), F₁ (fuse, standard $\frac{1}{2}$ ampere) or power cord bad.

*** Symptom:** No voltage at TP3.

Probable Cause: T₁ (transformer), D₁ (bridge rectifier), F₁ (fuse, standard $\frac{1}{2}$ ampere) or power cord bad.

*** Symptom:** No voltage at TP4.

Probable Cause: U₁, U₂, U₃, U₄, U₅ (operational amplifiers) or VR₁ (voltage regulator) shorted or short on the circuit board. No unregulated supply voltage of 24.000 Vdc.

*** Symptom:** No voltage at TP5 or TB1-5.

Probable Cause: U₁, U₂, U₃, U₄, U₅ (operational amplifiers) or VR₂ (voltage regulator) shorted or short on the circuit board. No unregulated, negative supply voltage of -24.000 Vdc.

*** Symptom:** No voltage at TP6.

Probable Cause: VR3 (voltage regulator) shorted or short on the circuit board. No unregulated supply voltage of either 24.000 Vdc or 15.000 Vdc (depending on jumper configuration). Faulty or missing jumper.

*** Symptom:** No voltage at TP7.

Probable Cause: No unregulated supply voltage of 15.000 Vdc, R12 (resistor) or R14 (potentiometer) open, D4 (voltage regulator), D5 and D6 (diodes) shorted, U1 loading down the reference voltage of 2.490 Vdc or short on circuit board.

Note: If a low or high voltage is measured at TP4, R14 (potentiometer) may be adjusted improperly. If necessary, adjust R14 up or down until the DVM reading is 2.490 Vdc.

*** Symptom:** No voltage at TP8.

Probable Cause: No reference voltage of 2.490 Vdc, U1 (operational amplifier) bad, or R15 (resistor) or R16 (potentiometer) open.

Note: If a low or high voltage is measured at TP8, R14 (potentiometer) or R16 (potentiometer) may be adjusted improperly or R13 (resistor) or R15 (resistor) are of improper values. If necessary, adjust R16 up or down until the DVM reading is -5.000 Vdc. You must first check to verify if the reference voltage at TP7 is 2.490 Vdc.

*** Symptom:** No voltage at TP9.

Probable Cause: Kurz thermal mass flow sensor disconnected, Q1 (heat sink transistor) on current-transmitter board bad, no bridge voltage, no unregulated supply voltage of 24.000 Vdc getting to the current-transmitter board, faulty two-wire loop connection between current-transmitter board and linearizer board, E9 (jumper) missing or faulty or U1 (operational amplifier) bad.

*** Symptom:** No bridge voltage on the current-transmitter board.

Probable Cause: Refer to the symptom of no voltage at TP9.

*** Symptom:** No nonlinear 0.000 to 5.000 Vdc corresponding to zero flow rate and specified maximum flow rate at TB1-4.

Probable Cause: No bridge voltage, U1 (operational amplifier) bad, jumper (E9) missing or faulty.

*** Symptom:** Low nonlinear 0.000 to 5.000 Vdc at TB1-4.

Probable Cause: R19 (potentiometer) or R21 (potentiometer) adjustment faulty, signal being loaded down by P.C.B, TP8 voltage drifting.

*** Symptom:** No linear output voltage.

Probable Cause: No input voltage, U2 (operational amplifier) bad, signal being loaded down.

*** Symptom:** Linear 0.000 to 5.000 Vdc reading is incorrect.

Probable Cause: Wrong flow range being used for unit, nonlinear 0.000 to 5.000 Vdc input to linear 0.000 to 5.000 Vdc output is adjusted improperly, faulty component in linear section.

*** Symptom:** Linear voltage output at TB1-2 above 10.000 Vdc continuous.

Probable Cause: Nonlinear 0.000 to 5.000 Vdc input to high and stay high (possible bad sensor), feedback resistor summing stage of linear section open, break-point amplifier railed out due to a faulty component.



KURZ SERVICE ORDER WORK SHEET

Account Name: Honeywell		Account #: 35025100		Final Entry:	
P.O. Number: Christine Clausung		P.O. Date: 4-11-12		P.O. Received Date: 4-11-12	
Kurz Customer Order #: 631648		RMA #: 0319HONJG		Sales Initials: JIG	
Accounting Initials:		Date Authorized: 4-12-12			
Sales Rep Company		Rep #	Booking Credit %	Sales Value	Commission Amount
1	Patten Systems	752	100	8990.00	
2					
3					
4					
Request Date:		Ship By:		Terms: CC	
Ship Date:		Arrive By:		Ship Via: UPS grnd #911487	
E-mail:		Email receipts to christine.clausung@honeywell.com			
Comments:		We will be doing a partial shipment. We will send s/n's- MD3719A, MD3668B & MD3661A first and repairs will go after and we will be expediting at no charge PER MARTY (split cost on credit card) Service tag #18182 will take about 4 weeks to return to customer. Sensor is on order			

Model:	454FTB-08-HHT		Serial No.:	MD3719A	
Range:	0-110 PPM	Gas:	AIR@65 PSIA		Previous Code: 629315
Service Tag #:	18183	Unit Location:	G1	Duct:	ID - .192440FT2 <input checked="" type="checkbox"/> Dimensions <input type="checkbox"/>
Operating Pressure:	65 PSIA		Operating Temp:		932F
Temp. Comp.:	1/A-Standard <input type="checkbox"/>	2/B-Elevated <input type="checkbox"/>	3/C-3 Data Sets <input type="checkbox"/>	4/D-4 Data Sets <input type="checkbox"/>	Special <input checked="" type="checkbox"/>
Necessary Work:	RECAL W/ 5 VTM				

Model:	454FTB-08-HHT		Serial No.:	MD3668B	
Range:	0-80 PPM	Gas:	AIR@70 PSIA		Previous Code: 629968
Service Tag #:	18180	Unit Location:	G1	Duct:	ID - .031468FT2 <input checked="" type="checkbox"/> Dimensions <input type="checkbox"/>
Operating Pressure:	70 PSIA		Operating Temp:		932F
Temp. Comp.:	1/A-Standard <input type="checkbox"/>	2/B-Elevated <input type="checkbox"/>	3/C-3 Data Sets <input type="checkbox"/>	4/D-4 Data Sets <input type="checkbox"/>	Special <input checked="" type="checkbox"/>
Necessary Work:	RECAL W/ 5 VTM				

Model:	454FTB-08-HHT		Serial No.:	MD3661A	
Range:	0-15 PPM	Gas:	AIR@70 PSIA		Previous Code: 629390
Service Tag #:	18181	Unit Location:	G1	Duct:	ID - .02053FT2 <input checked="" type="checkbox"/> Dimensions <input type="checkbox"/>
Operating Pressure:	70 PSIA		Operating Temp:		932F
Temp. Comp.:	1/A-Standard <input type="checkbox"/>	2/B-Elevated <input type="checkbox"/>	3/C-3 Data Sets <input type="checkbox"/>	4/D-4 Data Sets <input type="checkbox"/>	Special <input checked="" type="checkbox"/>
Necessary Work:	RECAL W/ 5 VTM				

Model:	454FTB-08-HHT		Serial No.:	MD3664B	
Range:	0-15 PPM	Gas:	AIR@70 PSIA		Previous Code: 629390
Service Tag #:	18185	Unit Location:	G1	Duct:	ID - .02053FT2 <input checked="" type="checkbox"/> Dimensions <input type="checkbox"/>
Operating Pressure:	70 PSIA		Operating Temp:		932F
Temp. Comp.:	1/A-Standard <input type="checkbox"/>	2/B-Elevated <input type="checkbox"/>	3/C-3 Data Sets <input type="checkbox"/>	4/D-4 Data Sets <input type="checkbox"/>	Special <input checked="" type="checkbox"/>
Necessary Work:	RECAL W/ 5 VTM & REPLACE SPECIAL SENSOR REF. DRAWING (WZ)-7001				

Model:	454FTB-08-HHT		Serial No.:	MD3663A	
Range:	0-15 PPM	Gas:	AIR@70 PSIA		Previous Code: 625039
Service Tag #:	18184	Unit Location:	G1	Duct:	ID - .020530FT2 <input checked="" type="checkbox"/> Dimensions <input type="checkbox"/>
Operating Pressure:	70 PSIA		Operating Temp:		932F
Temp. Comp.:	1/A-Standard <input type="checkbox"/>	2/B-Elevated <input type="checkbox"/>	3/C-3 Data Sets <input type="checkbox"/>	4/D-4 Data Sets <input type="checkbox"/>	Special <input checked="" type="checkbox"/>
Necessary Work:	RECAL W/ 5 VTM & REPLACE SC BRD 700479-06				

